



VKR DN 10÷50

PVC-U

DUAL BLOCK® regulating ball valve



VKR DN 10÷50

The VKR DUAL BLOCK® valve combines high reliability and safety aspects typical of VKD full bore ball valves with the new flow adjustment function with typical linear curve that meets the most stringent needs typical of industrial applications.



DUAL BLOCK® REGULATING BALL VALVE

- Connection system for solvent weld, threaded and flanged joints
- Patented **SEAT STOP®** ball carrier system that lets you micro-adjust seals and minimise the axial force effect
- Easy radial dismounting allowing quick replacement of O-rings and ball seats without any need for tools
- **PN16 True Union valve body** made for rigid PVC-U injection moulding equipped with built-in bores for actuation. ISO 9393 compliant test requisites
- Option of dismounting downstream pipes with the valve in the closed position
- High surface finish stem with double O-Ring and double connection key to ball
- **Integrated bracket** for valve anchoring
- Ball seat carrier can be adjusted using the **Easytorque adjustment kit**
- Actuation option: version with electric modulating actuator with 4-20 mA / 0-10 V inlet and 4-20 mA / 0-10 V outlet to monitor the position
- Valve suitable for carrying fluids that are clean and free of suspended particles

Technical specifications

Construction	2-way True Union adjusting ball valve with locked carrier and union nuts.
Size range	DN 10 ÷ 50
Nominal pressure	PN 16 with water at 20 °C
Temperature range	0 °C ÷ 60 °C
Coupling standards	<p>Solvent welding: EN ISO 1452, EN ISO 15493, BS 4346-1, DIN 8063, NF T54-028, ASTM D 2467, JIS K 6743. Pipe coupling as EN ISO 1452, EN ISO 15493, DIN 8062, NF T54-016, ASTM D 1785, JIS K 6741</p> <p>Thread: ISO 228-1, DIN 2999, ASTM D 2464, JIS B 0203</p> <p>Flanging system: ISO 7005-1, EN ISO 1452, EN ISO 15493, EN 558-1, DIN 2501, ANSI B.16.5 cl. 150, JIS B 2220</p>
Reference standards	<p>Construction criteria: EN ISO 16135, EN ISO 1452, EN ISO 15493</p> <p>Test methods and requirements: ISO 9393</p> <p>Installation criteria: DVS 2204, DVS 2221, UNI 11242</p> <p>Actuator couplings: ISO 5211</p>
Valve material	PVC-U
Seal material	EPDM, FKM (standard size O-Ring); PTFE (ball seats)
Control options	Manual control; electric actuator

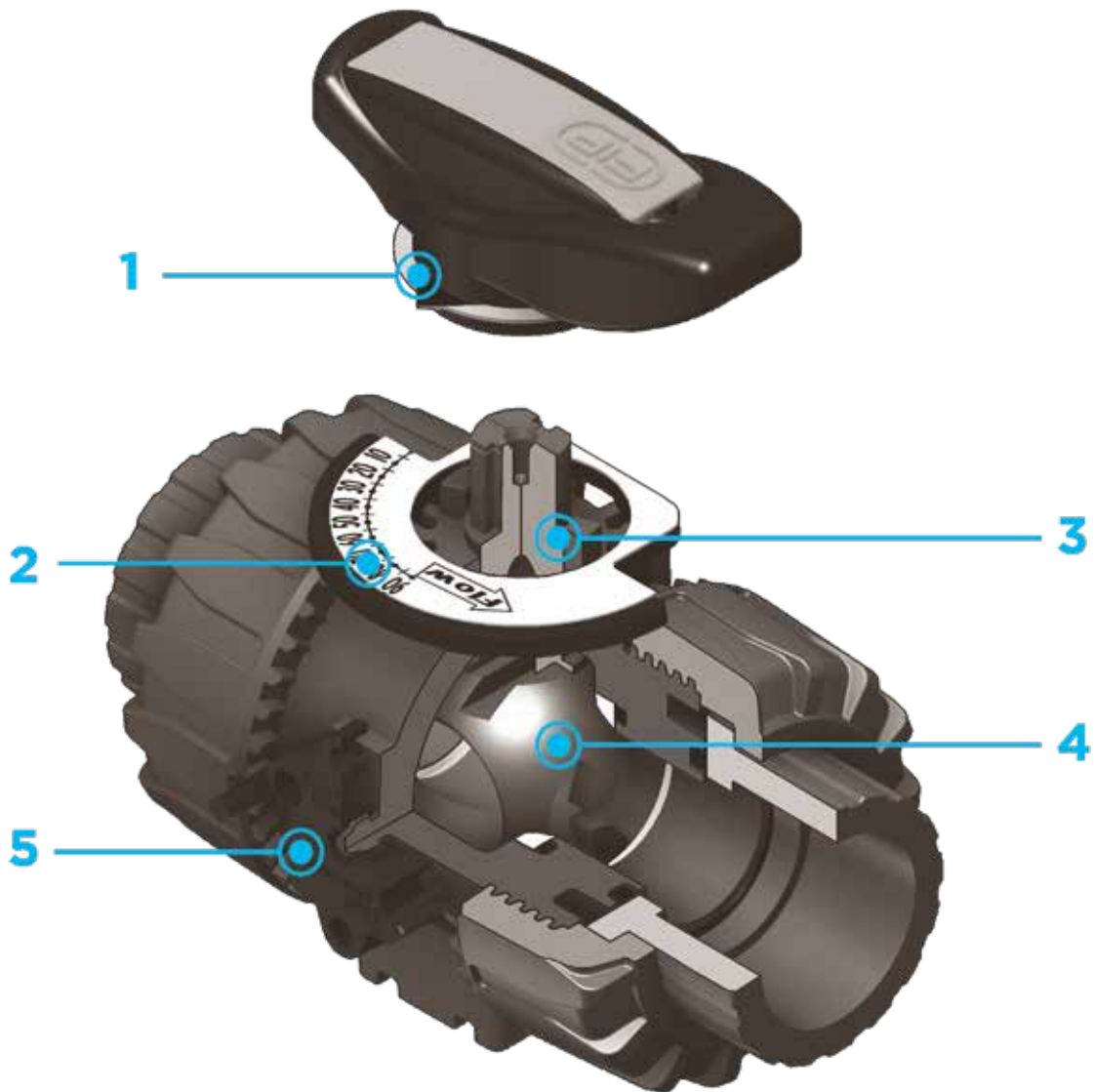

1 HIPVC ergonomic multifunctional handle with **position indicator** and tool to adjust the ball seat carrier

2 Flow direction and opening angle indication plate with **graduated scale with 5° detail** for clear and accurate readings

3 90° operating angle that permits **the use of standard** quarter turn **actuators**

4 The patented ball design provides **linear flow adjustment** throughout its range of operation even when the valve is open just a few

degrees and guarantees minimum pressure drops

5 Patented **DUAL BLOCK®** system: prevents union nuts from loosening even under extreme operating conditions: e.g. vibration or thermal expansion

TECHNICAL DATA

PRESSURE VARIATION ACCORDING TO TEMPERATURE

For water and harmless fluids to which the material is classified as CHEMICALLY RESISTANT. In other cases, a reduction of the nominal PN pressure is required (25 years with safety factor).



PRESSURE DROP GRAPH

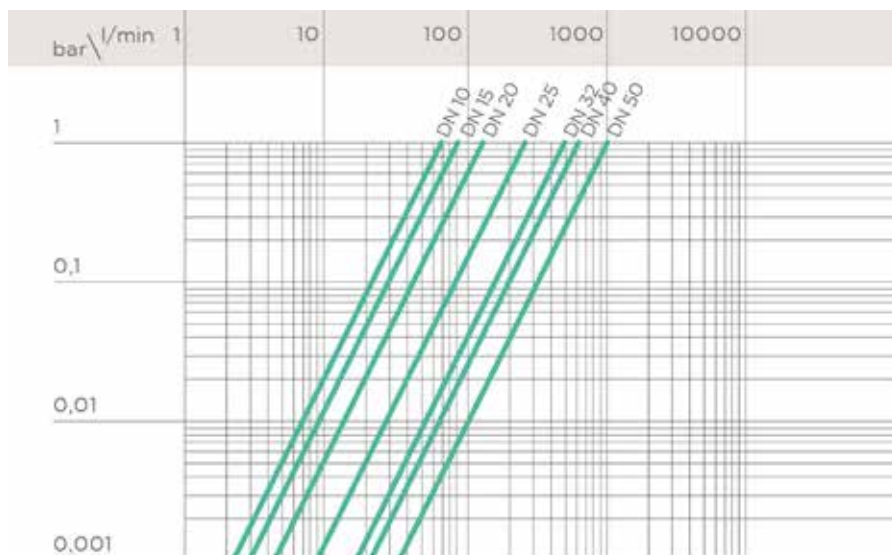

K_v100 FLOW COEFFICIENT

The K_v100 flow coefficient is the Q flow rate of litres per minute of water at a temperature of 20°C that will generate Δp= 1 bar pressure drop at a certain valve position. The Kv100 values shown in the table are calculated with the valve completely open.

DN	10	15	20	25	32	40	50
Kv100 l/min	83	135	256	478	592	1068	

RELATIVE FLOW COEFFICIENT DIAGRAM

The relative flow coefficient is the flow rate through the valve as a function of the degree of valve aperture.

Horizontal axis: Ball aperture angle
Vertical axis: Relative flow coefficient

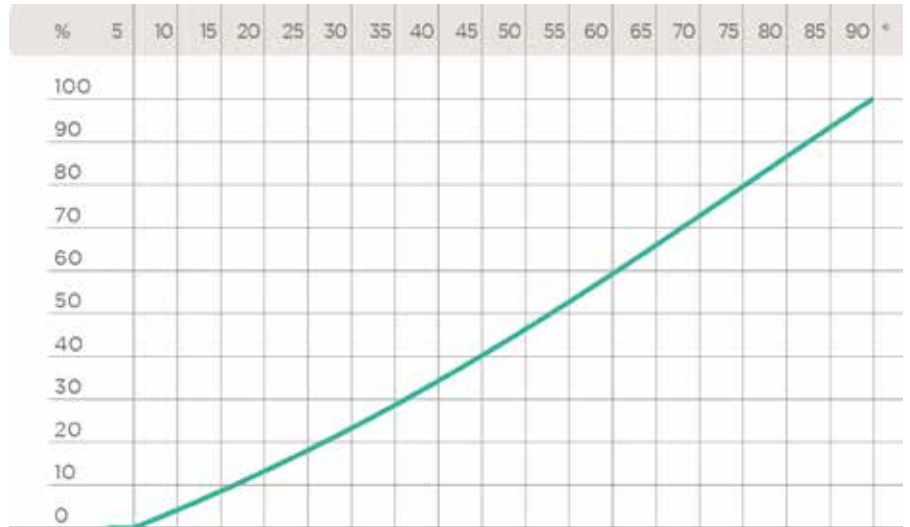

OPERATING TORQUE AT MAXIMUM WORKING PRESSURE

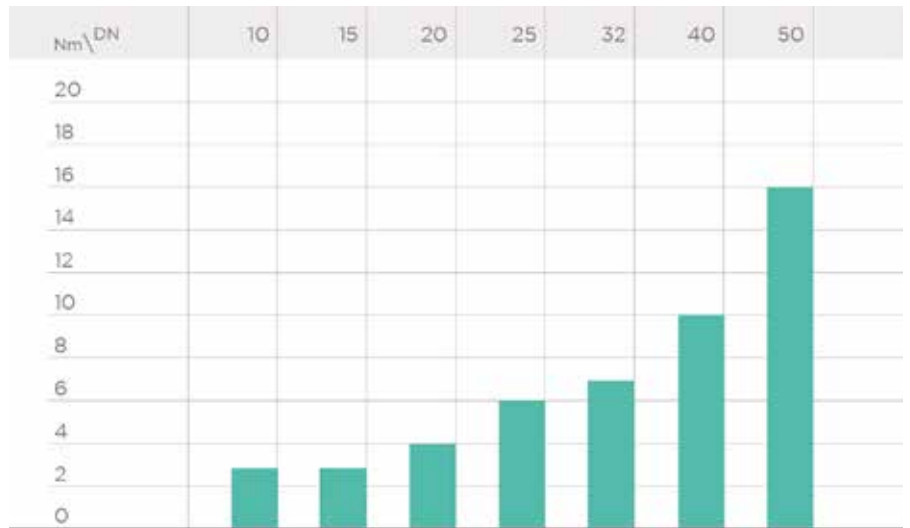

The information in this leaflet is provided in good faith. No liability will be accepted concerning technical data that is not directly covered by recognised international standards. FIP reserves the right to carry out any modification. Products must be installed and maintained by qualified personnel.

DIMENSIONS

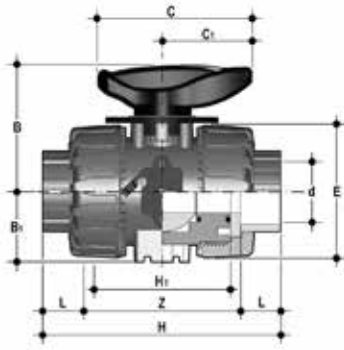

VKRIV

DUAL BLOCK® regulating ball valve with female ends for solvent welding, metric series

d	DN	PN	B	B ₁	C	C ₁	E	H	H ₁	L	Z	g	EPDM code	FKM code
16	10	16	54	29	67	40	54	103	65	14	75	215	VKRIV016E	VKRIV016F
20	15	16	54	29	67	40	54	103	65	16	71	205	VKRIV020E	VKRIV020F
25	20	16	65	34,5	85	49	65	115	70	19	77	330	VKRIV025E	VKRIV025F
32	25	16	69,5	39	85	49	73	128	78	22	84	438	VKRIV032E	VKRIV032F
40	32	16	82,5	46	108	64	86	146	88	26	94	693	VKRIV040E	VKRIV040F
50	40	16	89	52	108	64	98	164	93	31	102	925	VKRIV050E	VKRIV050F
63	50	16	108	62	134	76	122	199	111	38	123	1577	VKRIV063E	VKRIV063F

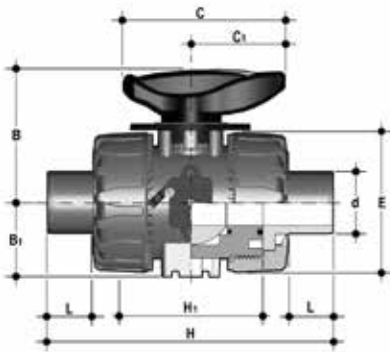

VKRDV

DUAL BLOCK® regulating ball valve with male ends for solvent welding, metric series

d	DN	PN	B	B ₁	C	C ₁	E	H	H ₁	L	g	EPDM code	FKM code
16	10	16	54	29	67	40	54	149	65	14	215	VKRDV016E	VKRDV016F
20	15	16	54	29	67	40	54	124	65	16	220	VKRDV020E	VKRDV020F
25	20	16	65	34,5	85	49	65	144	70	19	340	VKRDV025E	VKRDV025F
32	25	16	69,5	39	85	49	73	154	78	22	443	VKRDV032E	VKRDV032F
40	32	16	82,5	46	108	64	86	174	88	26	693	VKRDV040E	VKRDV040F
50	40	16	89	52	108	64	98	194	93	31	945	VKRDV050E	VKRDV050F
63	50	16	108	62	134	76	122	224	111	38	1607	VKRDV063E	VKRDV063F

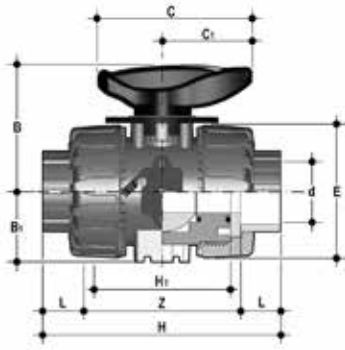

VKRLV

DUAL BLOCK® regulating ball valve with BS plain socket ends for solvent welding

d	DN	PN	B	B ₁	C	C ₁	E	H	H ₁	L	Z	g	EPDM code	FKM code
3/8"	10	16	54	29	67	40	54	103	65	14,5	74	210	VKRLV038E	VKRLV038F
1/2"	15	16	54	29	67	40	54	103	65	16,5	70	205	VKRLV012E	VKRLV012F
3/4"	20	16	65	34,5	85	49	65	115	70	19	77	335	VKRLV034E	VKRLV034F
1"	25	16	69,5	39	85	49	73	128	78	22,5	83	433	VKRLV100E	VKRLV100F
1" 1/4	32	16	82,5	46	108	64	86	146	88	26	94	703	VKRLV114E	VKRLV114F
1" 1/2	40	16	89	52	108	64	98	164	93	30	104	925	VKRLV112E	VKRLV112F
2"	50	16	108	62	134	76	122	199	111	36	127	1647	VKRLV200E	VKRLV200F

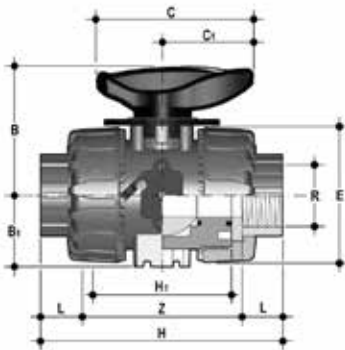

VKRFV

DUAL BLOCK® regulating ball valve with BSP threaded female ends

R	DN	PN	B	B ₁	C	C ₁	E	H	H ₁	L	Z	g	EPDM code	FKM code
3/8"	10	16	54	29	67	40	54	103	65	12	80	215	VKRFV038E	VKRFV038F
1/2"	15	16	54	29	67	40	54	110	65	15	80	210	VKRFV012E	VKRFV012F
3/4"	20	16	65	34,5	85	49	65	116	70	16	83	335	VKRFV034E	VKRFV034F
1"	25	16	69,5	39	85	49	73	134	78	19	96	448	VKRFV100E	VKRFV100F
1" 1/4	32	16	82,5	46	108	64	86	153	88	21	110	678	VKRFV114E	VKRFV114F
1" 1/2	40	16	89	52	108	64	98	156	93	21	113	955	VKRFV112E	VKRFV112F
2"	50	16	108	62	134	76	122	186	111	26	135	1667	VKRFV200E	VKRFV200F

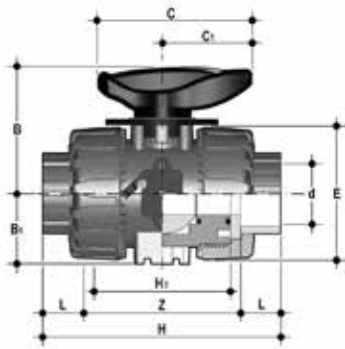

VKRAV

DUAL BLOCK® regulating ball valve with female ends for solvent welding, ASTM series

d	DN	PN	B	B ₁	C	C ₁	E	H	H ₁	L	Z	g	EPDM code	FKM code
3/8"	10	16	54	29	67	40	54	117	65	19,5	78	230	VKRAV038E	VKRAV038F
1/2"	15	16	54	29	67	40	54	117	65	22,5	72	215	VKRAV012E	VKRAV012F
3/4"	20	16	65	34,5	85	49	65	129	70	25,5	78	345	VKRAV034E	VKRAV034F
1"	25	16	69,5	39	85	49	73	142	78	28,7	84,6	448	VKRAV100E	VKRAV100F
1" 1/4	32	16	82,5	46	108	64	86	162	88	32	98	718	VKRAV114E	VKRAV114F
1" 1/2	40	16	89	52	108	64	98	172	93	35	102	975	VKRAV112E	VKRAV112F
2"	50	16	108	62	134	76	122	199	111	38,2	122,6	1712	VKRAV200E	VKRAV200F

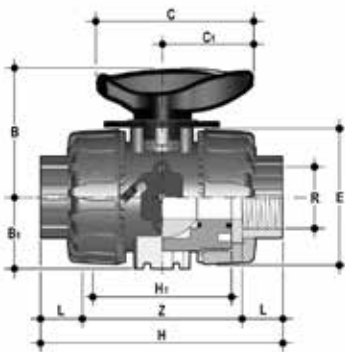

VKRNV

DUAL BLOCK® regulating ball valve with female ends, NPT thread

R	DN	PN	B	B ₁	C	C ₁	E	H	H ₁	L	Z	g	EPDM code	FKM code
3/8"	10	16	54	29	67	40	54	103	65	13,7	75,6	215	VKRNV038E	VKRNV038F
1/2"	15	16	54	29	67	40	54	111	65	17,8	75,4	210	VKRNV012E	VKRNV012F
3/4"	20	16	65	34,5	85	49	65	117	70	18	81	335	VKRNV034E	VKRNV034F
1"	25	16	69,5	39	85	49	73	135	78	22,6	89,8	448	VKRNV100E	VKRNV100F
1" 1/4	32	16	82,5	46	108	64	86	153	88	25,1	102,8	678	VKRNV114E	VKRNV114F
1" 1/2	40	16	89	52	108	64	98	156	93	24,7	106,6	955	VKRNV112E	VKRNV112F
2"	50	16	108	62	134	76	122	186	111	29,6	126,8	1667	VKRNV200E	VKRNV200F

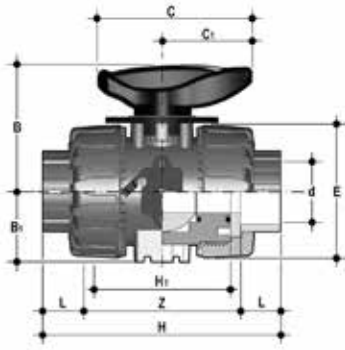

VKRJV

DUAL BLOCK® regulating ball valve with female ends for solvent welding, JIS series

d	DN	PN	B	B ₁	C	C ₁	E	H	H ₁	L	Z	g	EPDM code	FKM code
1/2"	15	16	54	29	67	40	54	131	65	30	71	225	VKRJV012E	VKRJV012F
3/4"	20	16	65	34,5	85	49	65	147	70	35	77	335	VKRJV034E	VKRJV034F
1"	25	16	69,5	39	85	49	73	164	78	40	84	448	VKRJV100E	VKRJV100F
1" 1/4	32	16	82,5	46	108	64	86	182	88	44	94	728	VKRJV114E	VKRJV114F
1" 1/2	40	16	89	52	108	64	98	212	93	55	102	1015	VKRJV112E	VKRJV112F
2"	50	16	108	62	134	76	122	248	111	63	122	1727	VKRJV200E	VKRJV200F

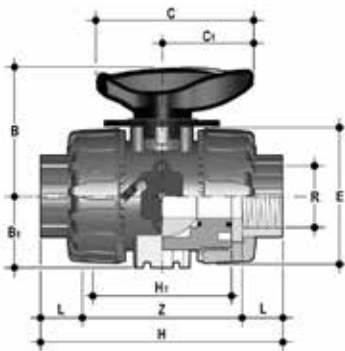

VKRGV

DUAL BLOCK® regulating ball valve with female ends, JIS thread

R	DN	PN	B	B ₁	C	C ₁	E	H	H ₁	L	Z	g	EPDM code	FKM code
1/2"	15	16	54	29	67	40	54	103	65	16	71	210	VKRGV012E	VKRGV012F
3/4"	20	16	65	34,5	85	49	65	115	70	19	77	330	VKRGV034E	VKRGV034F
1"	25	16	69,5	39	85	49	73	128	78	22	84	438	VKRGV100E	VKRGV100F
1" 1/4	32	16	82,5	46	108	64	86	146	88	25	96	678	VKRGV114E	VKRGV114F
1" 1/2	40	16	89	52	108	64	98	164	93	26	112	975	VKRGV112E	VKRGV112F
2"	50	16	108	62	134	76	122	199	111	31	137	1627	VKRGV200E	VKRGV200F

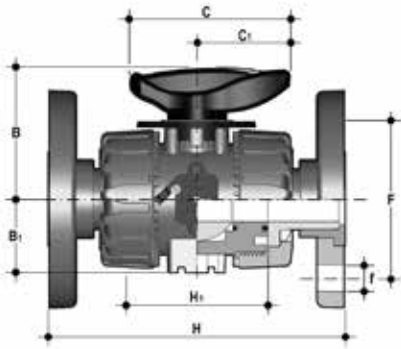

VKROV

DUAL BLOCK® regulating ball valve with EN/ISO/DIN fixed flange, drilled PN10/16. Face to face according to EN 558-1

d	DN	PN	B	B ₁	C	C ₁	F	H	H ₁	U	f	Sp	g	EPDM code	FKM code
20	15	16	54	29	67	40	65	130	65	4	14	11	375	VKROV020E	VKROV020F
25	20	16	65	34,5	85	49	75	150	70	4	14	14	590	VKROV025E	VKROV025F
32	25	16	69,5	39	85	49	85	160	78	4	14	14	713	VKROV032E	VKROV032F
40	32	16	82,5	46	108	64	100	180	88	4	18	14	1108	VKROV040E	VKROV040F
50	40	16	89	52	108	64	110	200	93	4	18	16	1485	VKROV050E	VKROV050F
63	50	16	108	62	134	76	125	230	111	4	18	16	2347	VKROV063E	VKROV063F

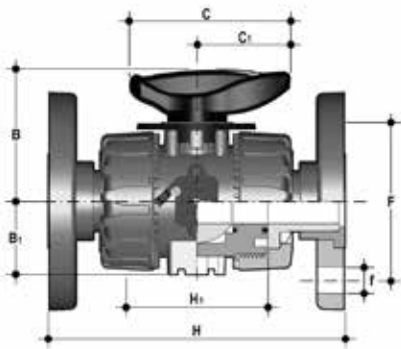

VKROAV

DUAL BLOCK® regulating ball valve with ANSI B16.5 cl.150#FF fixed flange

d	DN	PN	B	B ₁	C	C ₁	F	H	H ₁	U	f	Sp	g	EPDM code	FKM code
1/2"	15	16	54	29	67	40	60,3	143	65	4	15,9	11	460	VKROAV012E	VKROAV012F
3/4"	20	16	65	34,5	85	49	69,9	172	70	4	15,9	14	632	VKROAV034E	VKROAV034F
1"	25	16	69,5	39	85	49	79,4	187	78	4	15,9	14	853	VKROAV100E	VKROAV100F
1" 1/4	32	16	82,5	46	108	64	88,9	190	88	4	15,9	14	1313	VKROAV114E	VKROAV114F
1" 1/2	40	16	89	52	108	64	98,4	212	93	4	15,9	16	1669	VKROAV112E	VKROAV112F
2"	50	16	108	62	134	76	120,7	234	111	4	19,1	16	2577	VKROAV200E	VKROAV200F

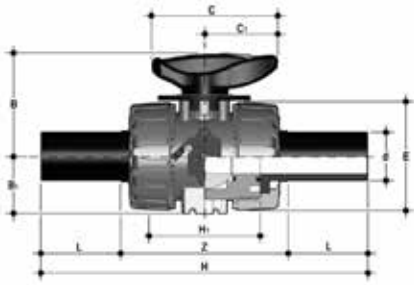

VKRBEV

Dual Block® regulating ball valve with PE100 SDR 11 male end connectors for butt welding or electrofusion (CVDE)

d	DN	PN	B	B ₁	C	C ₁	E	H	H ₁	L	Z	g	EPDM code	FKM code
20	15	16	54	29	67	40	54	175	65	40,5	94	220	VKRBEV020E	VKRBEV020F
25	20	16	65	34,5	85	49	65	213	70	54	106	340	VKRBEV025E	VKRBEV025F
32	25	16	69,5	39	85	49	73	228	78	56	117	443	VKRBEV032E	VKRBEV032F
40	32	16	82,5	46	108	64	86	247	88	56	131	693	VKRBEV040E	VKRBEV040F
50	40	16	89	52	108	64	98	271	93	60,5	145	945	VKRBEV050E	VKRBEV050F
63	50	16	108	62	134	76	122	300	111	65,5	161	1607	VKRBEV063E	VKRBEV063F

ACCESSORIES

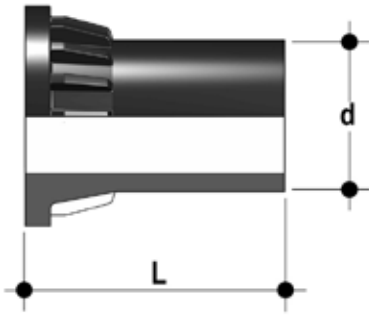

CVDE

Long spigot PE100 end connectors for joints with electrofusion fittings or for butt welding

d	DN	PN	L	SDR	Code
20	15	16	55	11	CVDE11020
25	20	16	70	11	CVDE11025
32	25	16	74	11	CVDE11032
40	32	16	78	11	CVDE11040
50	40	16	84	11	CVDE11050
63	50	16	91	11	CVDE11063

PMKD

Wall mounting plate

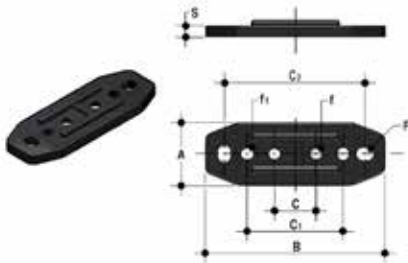

d	DN	A	B	C	C ₁	C ₂	F	f	f ₁	S	Code
16	10	30	86	20	46	67,5	6,5	5,3	5,5	5	PMKD1
20	15	30	86	20	46	67,5	6,5	5,3	5,5	5	PMKD1
25	20	30	86	20	46	67,5	6,5	5,3	5,5	5	PMKD1
32	25	30	86	20	46	67,5	6,5	5,3	5,5	5	PMKD1
40	32	40	122	30	72	102	6,5	6,3	6,5	6	PMKD2
50	40	40	122	30	72	102	6,5	6,3	6,5	6	PMKD2
63	50	40	122	30	72	102	6,5	6,3	6,5	6	PMKD2

Easytorque Kit

Kit for ball seat carrier tightening adjustment for DUAL BLOCK® DN 10+50 series valves



d	DN	Tightening torque recommended*	Code
3/8"-1/2"	10-15	3 N m - 2,21 Lbf ft	KET01
3/4"	20	4 N m - 2,95 Lbf ft	KET01
1"	25	5 N m - 3,69 Lbf ft	KET01
1" 1/4	32	5 N m - 3,69 Lbf ft	KET01
1" 1/2	40	7 N m - 5,16 Lbf ft	KET01
2"	50	9 N m - 6,64 Lbf ft	KET01

*calculated in ideal installation conditions

FASTENING AND SUPPORTING

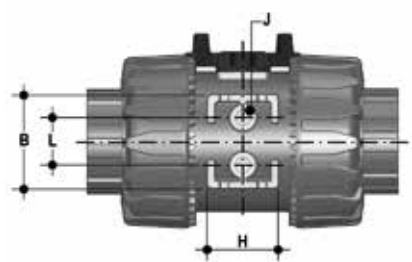

All valves, whether manual or driven, must be adequately supported in many applications.

The VKR valve series is therefore ready to be equipped with threaded supporting brackets (optional) that permits direct anchoring of the valve body without the need of other components.

For wall installation, dedicated PMKD mounting plates which are available as accessories can be used. These plates should be fastened to the valve before wall installation.

PMKD plates also allow VKR valve alignment with FIP ZIKM pipe clips as well as allowing different sizes of valves to be aligned.

d	DN	g	H	L	J*
16	10	31,5	27	20	M4 x 6
20	15	31,5	27	20	M4 x 6
25	20	40	30	20	M4 x 6
32	25	40	30	20	M4 x 6
40	32	50	35	30	M6 x 10
50	40	50	35	30	M6 x 10
63	50	60	40	30	M6 x 10

* With threaded inserts

COMPONENTS

EXPLODED VIEW

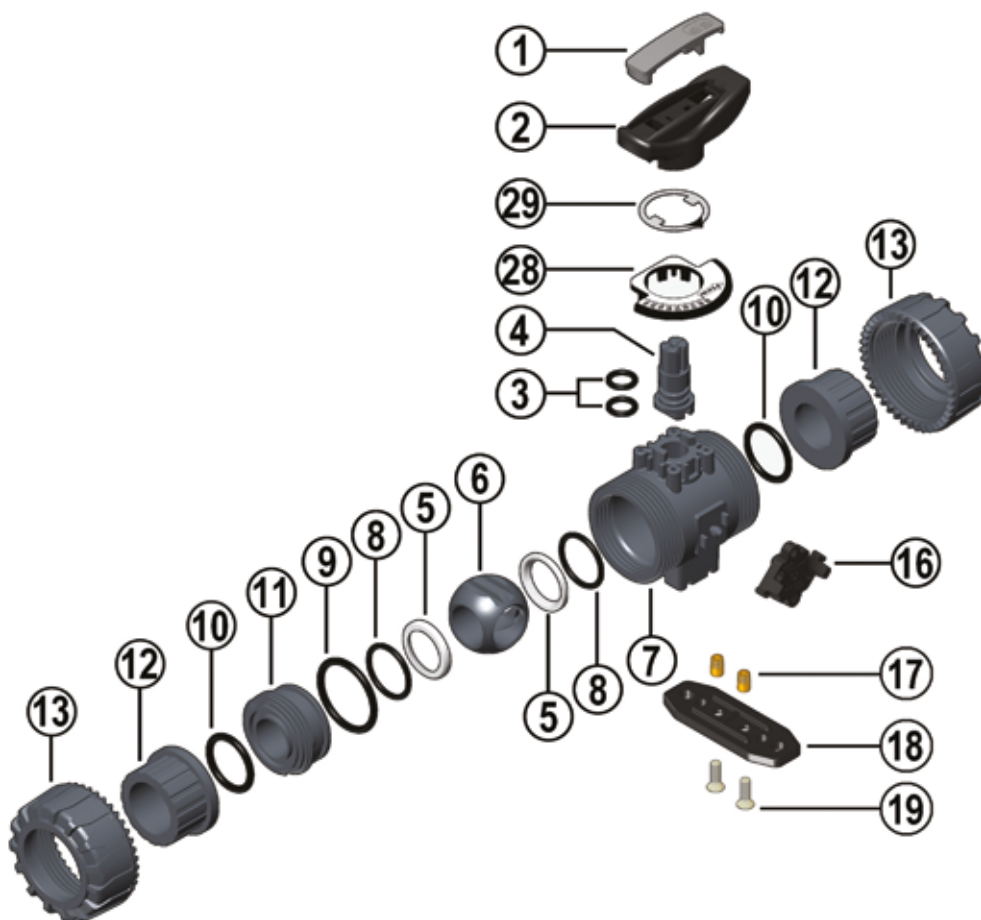

- | | | | | | |
|----------|----------------------------------|-----------|------------------------------------|-----------|---|
| 1 | Handle insert (PVC-U - 1) | 8 | Ball seat O-Rings (EPDM-FKM - 2)* | 16 | DUAL BLOCK® (POM - 1) |
| 2 | Handle (HIPVC - 1) | 9 | Radial seal O-Ring (EPDM-FKM - 1)* | 17 | Threaded inserts (STAINLESS steel or Brass - 2)** |
| 3 | Stem O-ring (EPDM-FKM - 2)* | 10 | Socket seal O-Ring (EPDM-FKM - 2)* | 18 | Distance plate (PP-GR - 1)** |
| 4 | Stem (PVC-U - 1) | 11 | Ball seat carrier (PVC-U - 1) | 19 | Screw (STAINLESS steel - 2)** |
| 5 | Ball seat (PTFE - 2)* | 12 | End connector (PVC-U - 2)* | 28 | Graduated plate (POM-PVC - 1) |
| 6 | Patented ball design (PVC-U - 1) | 13 | Union nut (PVC-U - 2) | 29 | Indicator (PVC - 1) |
| 7 | Body (PVC-U - 1) | | | | |

* Spare parts

** Accessories

The component material and quantity supplied are indicated in the parentheses.

DISASSEMBLY

- 1) Isolate the valve from the line (release the pressure and empty the pipeline).
- 2) Unlock the union nuts by pressing the lever on the DUAL BLOCK® (16) along the axis and separate it from the union nut (fig. 1). It is also possible to completely remove the block device from the body of the valve.
- 3) Fully unscrew the union nuts (13) and extract the body sideways.
- 4) Before dismounting, hold the valve in a vertical position and open it 45° to drain any liquid that might remain.
- 5) After closing the valve, remove the special insert (1) from the handle (2) and push the two projecting ends into the corresponding recesses on the ball seat carrier (11). Rotate the stop ring anti-clockwise to extract it.
- 6) Pull the handle (2) upwards to remove it from the valve stem (4).
- 7) Make sure that the position indicator (29) remains properly fastened to the handle (2).
- 8) Press on the ball from the side opposite the "REGULAR - ADJUST" label, being sure not to scratch it, until the ball seat carrier exits (11), then extract the ball (6).
- 9) Press the stem (4) inwards until it exits the valve body.
- 10) All the O-rings (3, 8, 9, 10) and PTFE ball seats (5) must be removed from their grooves, as shown in the exploded view.

ASSEMBLY

- 1) All the O-rings (3, 8, 9, 10) must be inserted in their grooves as shown in the exploded view.
- 2) Insert the stem (4) from inside the body (7).
- 3) Place the PTFE ball seats (5) in the housings in the body (7) and in the ball seat carrier (11).
- 4) Insert the ball (6) in the body as shown in Fig. 3
- 5) Screw the carrier (11) into the body and tighten up in the clockwise direction using the special insert (1) to limit stop.
- 6) Position the indicator (29) on the handle with the pointer set to 0 on the graduated scale while making sure that the valve is in the closed position (fig. 2-3).
- 7) Insert the handle (2) with the insert (1) in its housing on the stem (4).
- 8) Insert the valve between the end connectors (12) making sure that they match the direction of flow shown on the plate (fig. 2) then tighten the union nuts (13) making sure that the socket seal O-rings (10) do not come out of their grooves.



Note: during assembly operations, it is advisable to lubricate the rubber seals. Mineral oils are not recommended for this task as they react aggressively with EPDM rubber.

Fig. 1



Fig. 2



Fig. 3



INSTALLATION

Before proceeding with installation, please follow these instructions carefully:

- 1) Check that the pipes to be connected to the valve are aligned in order to avoid mechanical stress on the threaded joints.
 - 2) Check that the DUAL BLOCK® union nut locking device (16) is fitted to the valve body.
 - 3) To release the union nuts (13), axially press the release lever to separate the lock and then unscrew it in the counter-clockwise direction.
 - 4) Unscrew the union nuts (13) and insert them on the pipe segments.
 - 5) Solvent weld or screw the end connectors (12) onto the pipe ends.
 - 6) Position the valve between the pipe end connectors making sure the that direction of flow is the same as shown on the plate (Fig.4). Hand tighten the union nuts in the clockwise direction. Do not use a wrench or other tools which might damage the surface.
 - 7) Lock the union nuts by returning the DUAL BLOCK® to its housing, pressing on it until the hinges lock on the nuts.
 - 8) If necessary, support the pipework with FIP pipe clips or by means of the carrier built into the valve itself (see paragraph "fastening and supporting").
- Seals can be adjusted using the removable insert on the handle. The seals can be installed later with the valve installed on the pipe by simply tightening the union nuts. This "micro adjustment", only possible with FIP valves thanks to the patented "Seat stop system", allows the seal to be recovered where PTFE ball seats are worn due to a high number of operations. The Easytorque kit can also be used for micro adjustments (fig. 5).

WARNINGS

Always avoid sudden closing operations and protect the valve from accidental operations.

Fig. 4



Fig. 5

