



VEE DN 65÷100

PVC-U

Easyfit 2-way ball valve



VEE DN 65÷100

FIP and Giugiaro Design designed and developed VEE Easyfit, the innovative True Union ball valve that permits simple and safe installation for reliable service over time.



EASYFIT 2-WAY BALL VALVE

- **Patented Easyfit system:** innovative mechanism that lets you use the quick release handle to adjust the ball carrier
- Connection system for solvent weld and threaded joints
- **Valve material compatibility** (PVC-U) with water, drinking ware and other food substances according to **current regulations**
- Easy radial dismounting allowing quick replacement of O-rings and ball seats without any need for tools
- **PN16 True Union valve body** made for PVC-U injection moulding and European Directive 2014/68/EU (PED) compliant for pressurised equipment. ISO 9393 compliant test requirements
- Valve body with built-in anchoring frame for the special **Power Quick Easyfit module** dedicated to the installation of pneumatic and electric actuators or accessories
- Option of dismounting downstream pipes with the valve in the closed position
- Floating **full bore ball** with high surface finish made in CNC work stations to achieve precise dimensional tolerance and high surface finish

Technical specifications	
Construction	Easyfit 2-way True Union ball valve with locked carrier
Size range	DN 65 ÷ 100
Nominal pressure	PN 16 with water at 20 °C
Temperature range	0 °C ÷ 60 °C
Coupling standards	<p>Solvent welding: EN ISO 1452, EN ISO 15493, BS 4346-1, DIN 8063, NF T54-028, ASTM D 2467, JIS K 6743. Pipe coupling capacity according to EN ISO 1452, EN ISO 15493, DIN 8062, NF T54-016, ASTM D 1785, JIS K 6741</p> <p>Thread: ISO 228-1, DIN 2999, ASTM D 2467 JIS B 0203.</p>
Reference standards	<p>Construction criteria: EN ISO 16135, EN ISO 1452, EN ISO 15493</p> <p>Test methods and requirements: ISO 9393</p> <p>Installation criteria: DVS 2204, DVS 2221, UNI 11242</p> <p>Actuator couplings: ISO 5211</p>
Valve material	PVC-U
Seal material	EPDM (standard size O-Ring); PE (ball seats)
Control options	Manual control

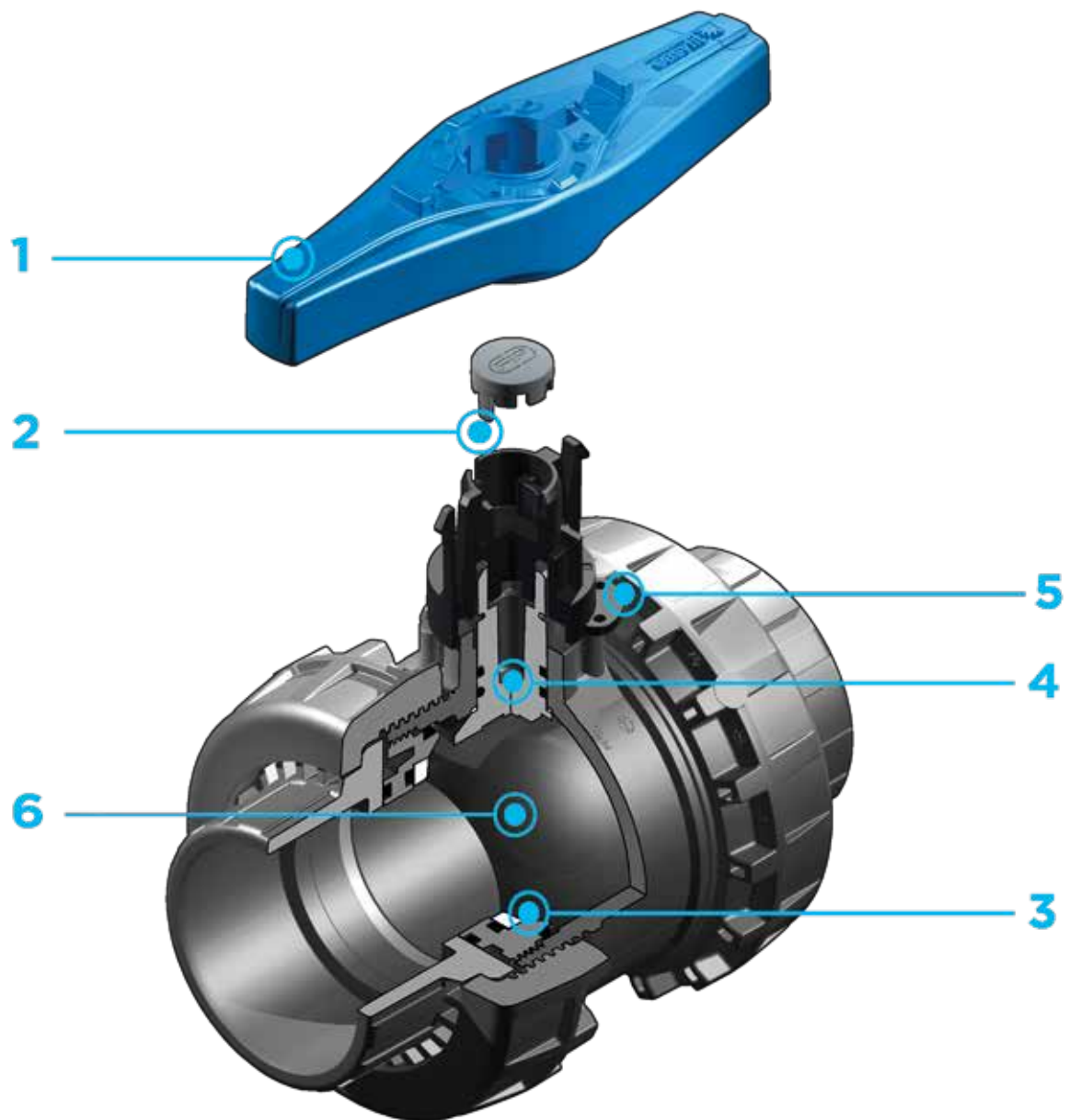

1 Innovative quick release Easyfit handle made up of a central hub firmly coupled with the stem by a **dual spoke grip** that can be released from the hub with a simple operation and used as a **ball seat adjustment tool**

2 Settings for the customisable Labelling System using the LCE module (available as an accessory). The grey protection plug housed on the central hub can be replaced with the

transparent plug and customisable tag holder with the LSE set (available as an accessory). The **customisation lets you identify the valve on the system** according to specific needs

3 PE seal system with locked carrier adjustable via the Easyfit quick release handle

4 Stem with high surface finish and double O-Ring and PTFE anti-

friction disk that limits friction to a minimum and grants excellent operating torque

5 Valve body set for SHE kit installation (available as an accessory) that blocks the closing and opening manoeuvres with a lock

6 Machined high surface finish ball that guarantees a smooth operation and increased reliability

TECHNICAL DATA

PRESSURE VARIATION ACCORDING TO TEMPERATURE

For water and harmless fluids to which the material is classified as CHEMICALLY RESISTANT. In other cases, a reduction of the nominal PN pressure is required (25 years with safety factor).



PRESSURE DROP GRAPH

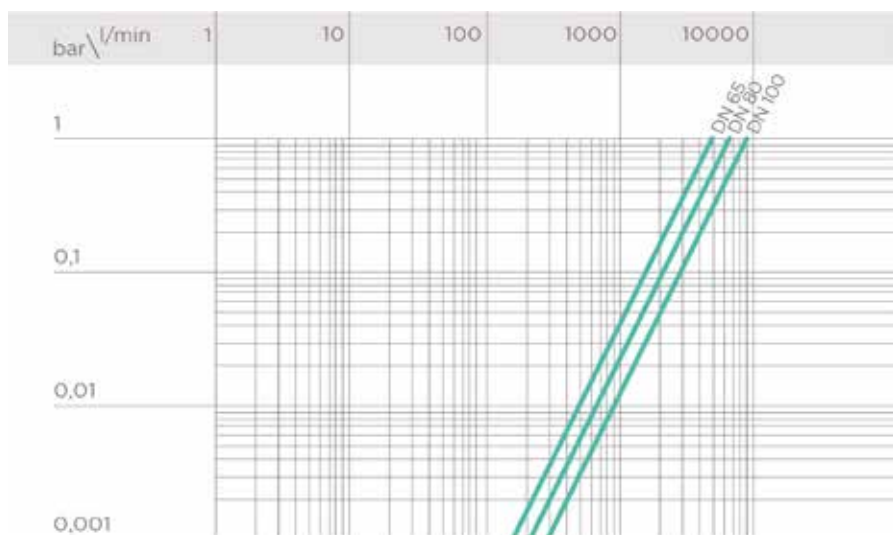

K_v100 FLOW COEFFICIENT

The K_v100 flow coefficient is the Q flow rate of litres per minute of water at a temperature of 20°C that will generate Δp= 1 bar pressure drop at a certain valve position. The Kv100 values shown in the table are calculated with the valve completely open.

DN	65	80	100
K _v 100 l/min	5000	7000	9400

OPERATING TORQUE AT MAXIMUM WORKING PRESSURE

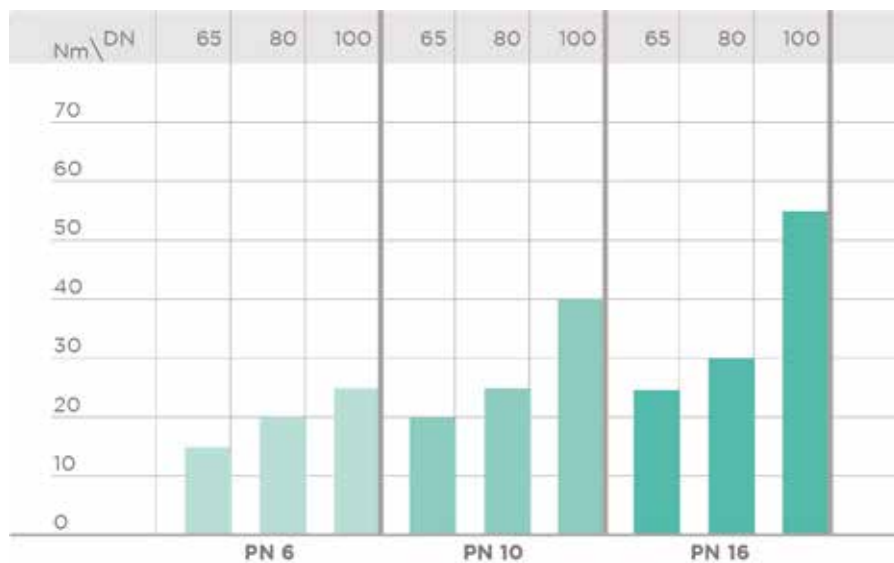

The information in this leaflet is provided in good faith. No liability will be accepted concerning technical data that is not directly covered by recognised international standards. FIP reserves the right to carry out any modification. Products must be installed and maintained by qualified personnel.

DIMENSIONS



VEEIV

Easyfit 2-way ball valve with female ends for solvent welding, metric series

d	DN	PN	B	C	C ₁	E	H	L	Z	g	Code
75	65	16	142	214	115	157	211	44	123	2750	VEEIV075E
90	80	16	151	239	126	174	248	51	146	3432	VEEIV090E
110	100	16	174,5	270	145	212	283	61	161	5814	VEEIV110E



VEEFV

Easyfit 2-way ball valve with BSP threaded female ends

R	DN	PN	B	C	C ₁	E	H	L	Z	g	Code
2 1/2"	65	16	142	214	115	157	211	30,2	150,6	2750	VEEFV212E
3"	80	16	151	239	126	174	248	33,3	181,4	3432	VEEFV300E
4"	100	16	174,5	270	145	212	283	39,3	204,4	5814	VEEFV400E



VEELV

Easyfit 2-way ball valve with female ends, BS series

d	DN	PN	B	C	C ₁	E	H	L	Z	g	Code
2 1/2"	65	16	142	214	115	157	211	44	123	2750	VEEIV075E
3"	80	16	151	239	126	174	248	51	146	3432	VEELV300E
4"	100	16	174,5	270	145	212	283	63	157	5814	VEELV400E

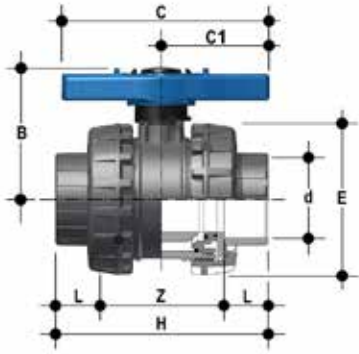

VEEAV

Easyfit 2-way ball valve with female ends, ASTM series

d	DN	PN	B	C	C ₁	E	H	L	Z	g	Code
2"1/2	65	16	142	214	115	157	211	44,5	122	2750	VEEAV212E
3"	80	16	151	239	126	174	248	48	152	3432	VEEAV300E
4"	100	16	174,5	270	145	212	283	57,5	168	5814	VEEAV400E



VEENV

Easyfit 2-way ball valve with female ends, NPT thread

R	DN	PN	B	C	C ₁	E	H	L	Z	g	Code
2"1/2	65	16	142	214	115	157	211	33,2	144,6	2750	VEENV212E
3"	80	16	151	239	126	174	248	35,5	177	3432	VEENV300E
4"	100	16	174,5	270	145	212	283	37,6	207,8	5814	VEENV400E



VEEJV

Easyfit 2-way ball valve with female ends, JIS series

d	DN	PN	B	C	C ₁	E	H	L	Z	g	Code
2"1/2	65	16	142	214	115	157	243	61	121	2750	VEEJV212E
3"	80	16	151	239	126	174	272	64,5	143	3432	VEEJV300E
4"	100	16	174,5	270	145	212	332	84	164	5814	VEEJV400E

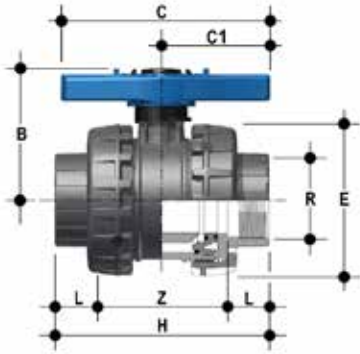

VEEGV

Easyfit 2-way ball valve with female ends, JIS thread

R	DN	PN	B	C	C ₁	E	H	L	Z	g	Code
2"1/2	65	16	142	214	115	157	211	35	141	2750	VEEGV212E
W	80	16	151	239	126	174	248	40	168	3432	VEEGV300E
4"	100	16	174,5	270	145	212	283	45	193	5814	VEEGV400E



VEEBEV

Easyfit 2-way ball valve with PE100 SDR 11 male end connectors for butt welding or electrofusion (CVDE)

d	DN	PN	B	C	C ₁	E	H	L	Z	g	Code
75	65	16	141,5	214	115	157	331	71	189	2286	VEEBEV075E
90	80	10	151	239	126	174	367	88	191	3059	VEEBEV090E
110	100	10	174,5	270	145	212	407	92	223	5814	VEEBEV110E

ACCESSORIES

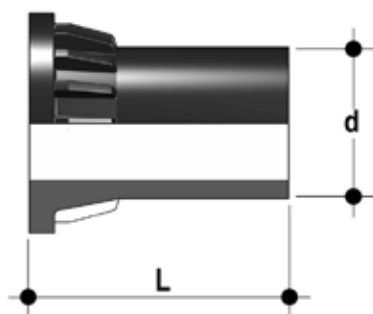

CVDE

Long spigot PE100 end connectors for joints with electrofusion fittings or for butt welding

d	DN	PN	L	SDR	Code
75	65	16	111	11	CVDE11075
90	80	16	118	11	CVDE11090VXE
110	100	16	127	11	CVDE11110VXE

PSE

Stem extension

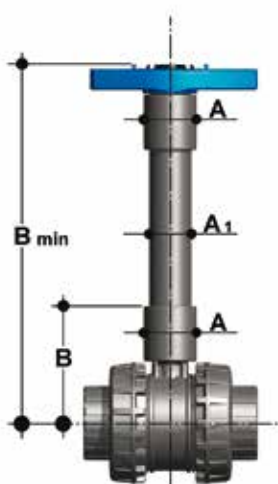

d	inch	DN	A	A ₁	B	B min	ISO pipe code	ASTM-BS pipe code
75	2 1/2	65	76	63	159	364	PSE090	PSE300
90	3"	80	76	63	166	371	PSE090	PSE300
110	4"	100	76	63	186	433	PSE110	PSE400

LCE

Transparent protection plug with tag holder



d	DN	VEE code
75	65	LCE040
90	80	LCE040
110	100	LCE040



LSE

Customisation and label printing set for Easyfit handle made up of precut adhesive sheets and software for guided label creation.

d	DN	VXE - VEE code
75	65	LSE040
90	80	LSE040
110	100	LSE040

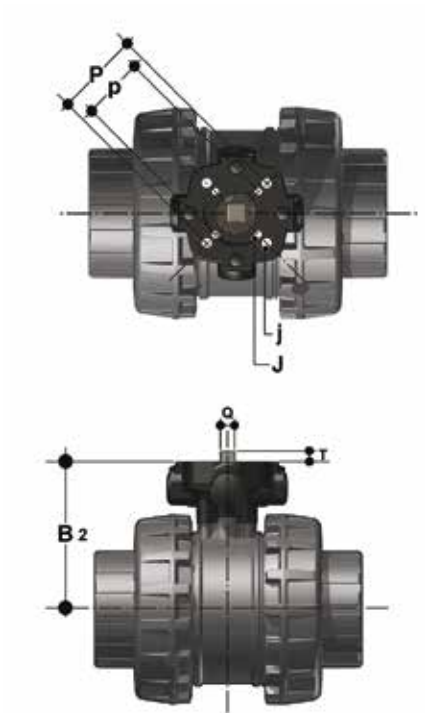

Power Quick Easyfit

The valve can be equipped with pneumatic or electric standard actuators and gearbox for heavy-duty operations, using the PP-GR module reproducing the drilling pattern foreseen by ISO 5211.

d	DN	B ₂	Q	T	p x j	P x J	Code
75	65	129	14	16	F05 x 6,5	F07 x 8,5	PQE090
90	80	136	14	16	F05 x 6,5	F07 x 8,5	PQE090
110	100	156	17	19	F05 x 6,5	F07 x 8,5	PQE110



SHE

Anti-tampering lock kit

d	DN	to be used with:	Code
75	65	VEE - VXE	SHE090
90	80	VEE - VXE	SHE090
110	100	VEE - VXE	SHE110

CUSTOMISATION

Fig. 1



Fig. 2



Fig. 3



The Easyfit VEE DN 65÷100 valve is set for the customisable Labelling System. This system lets you create special labels to insert in the handle. This makes it extremely easy to apply company logos, identification serial numbers or service indications such as, for example, the valve function in the system, the transported fluid, but also specific information for customer service, such as the customer name or installation date or location on the valves.

The grey protection plug (A) housed on the handle can be replaced with the specific LCE accessory module.

This module is made up of a rigid transparent water-resistant PVC plug (B) and white tag holder (C) made of the same material, one side of which bears the FIP logo (fig. 2).

The holder, inserted in the plug, can be removed and, once overturned, used for customisation by applying labels printed with the software supplied with the LSE set.

Proceed as follows to apply the label on the valve:

- 1) Release the handle from the central hub (D) and extract the grey plug (fig. 1).
- 2) Apply the adhesive label on tag holder included in the LCE set to align the profiles matching the tab position.
- 3) Insert tag holder in the transparent plug so that the label is protected from the elements (fig. 3).
- 4) Apply the transparent plug on the central hub matching the two fittings (one narrow and one wide) with the relevant housings.

Fig. 4



COMPONENTS

EXPLODED VIEW

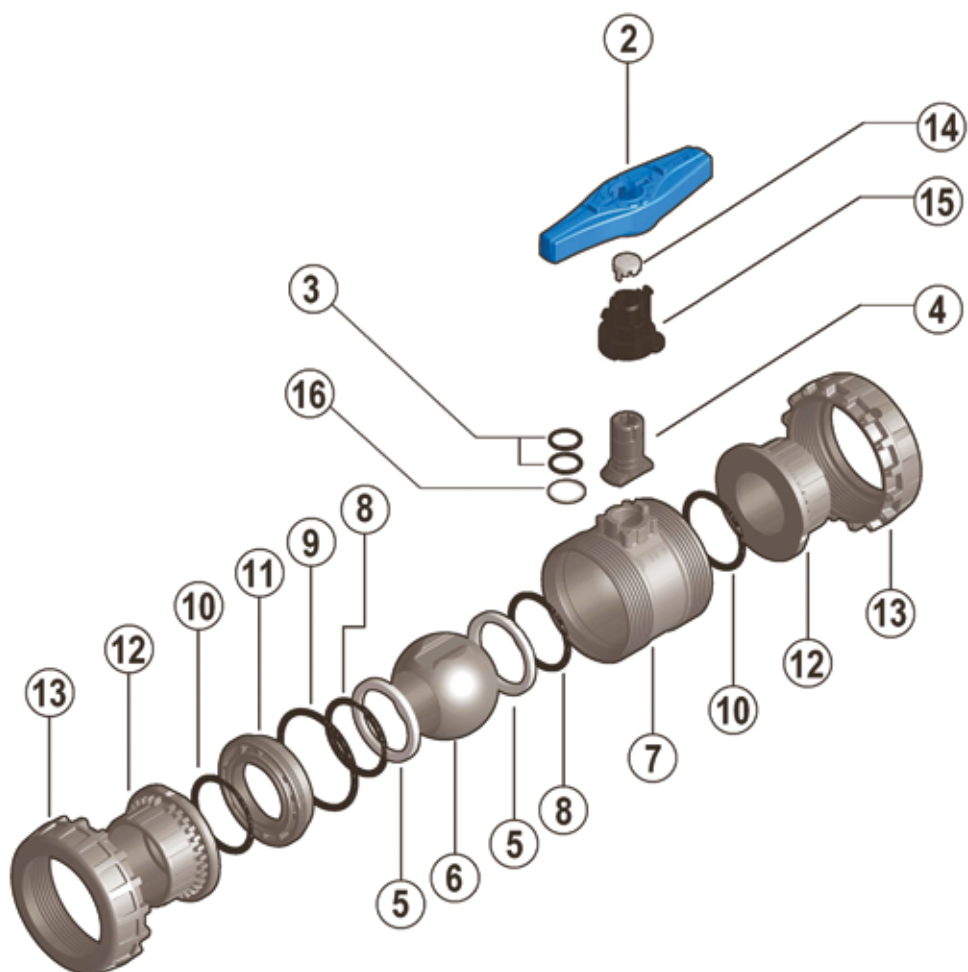

2 Easyfit quick release handle (HIPVC - 1)

3 Stem O-rings (EPDM** - 2)*

4 Stem (PVC-U - 1)

5 Ball seat (PE - 2)*

6 Ball (PVC-U - 1)*

7 Body (PVC-U - 1)

8 Ball seat O-Ring (EPDM - 2)*

9 Radial seal O-Ring (EPDM - 1)*

10 Socket seal O-Ring (EPDM - 2)*

11 Ball seat carrier (PVC-U - 1)

12 End connector (PVC-U - 2)

13 Union nut (PVC-U - 2)

14 Grey protection plug (PVC - 1)

15 Central hub (HIPVC - 1)

16 Anti-friction disk (PTFE - 1)*

* Spare parts

The component material and quantity supplied are indicated in the parentheses.

DISASSEMBLY

- 1) Isolate the valve from the line (release the pressure and empty the pipeline).
- 2) Fully unscrew the union nuts (13) from the valve body and slide the body out sideways (7) (fig. 7-8).
- 3) Before dismounting, hold the valve in a vertical position and open it 45° to drain any liquid that might remain.
- 4) Open the valve.
- 5) Remove the ball seat carrier (11) using the Easyfit quick release handle (2). Extract the handle from the central hub (15) pushing towards the hub hinge centres (fig. 5-6). Insert the two protrusion at the top of the handle in the carrier seats (11) and unscrew, extracting it by turning counter-clockwise (fig. 9-10).
- 6) Press on the ball (6) from the side opposite the "REGULAR" label, being sure not to scratch it, until the ball seat exits (11) then extract the ball (6).
- 7) Remove the central hub (15) firmly sliding it off the stem (4). Press the stem inwards and extract it from the body and remove the anti-friction disk (16).
- 8) Remove the O-Ring (3, 8, 9, 10) and ball seats (5) extracting them from their seats, as illustrated in the exploded view.

ASSEMBLY

- 1) All the O-rings (3, 8, 9, 10) must be inserted in their grooves as shown in the exploded view.
- 2) Place the anti-friction disk (16) on the stem (4) and insert it in the body (7).
- 3) Place the ball seats (5) in the housings in the body (7) and in the carrier (11).
- 4) Insert the ball (6) rotating it to the closed position.
- 5) Screw the carrier (11) into the body and tighten up in the clockwise direction using the handle (2) to limit stop.
- 6) Place the central hub (15) on the stem (4) firmly pressing down to match the internal hub key with one of the two seats on the stem.
- 7) Position the valve between the end connectors (12) and tighten the union nuts (13) clockwise making sure the socket seal O-Rings (10) do not exit the seats (fig. 7-8).
- 8) Reposition the handle (2) on the central hub (15) making sure the two grooves in the central handle bore match the two grooves on the side of the hub and slightly press down until the two hinges click.



Note: during assembly operations, it is advisable to lubricate the rubber seals. Mineral oils are not recommended for this task as they react aggressively with EPDM rubber.

Fig. 5



Fig. 6



Fig. 7



Fig. 8



INSTALLATION

Before proceeding with installation, please follow these instructions carefully:

- 1) Check that the pipes to be connected to the valve are aligned in order to avoid mechanical stress on the threaded joints.
- 2) Unscrew the union nuts (13) from the body (7) and insert them in the pipe segments.
- 3) Solvent weld or screw the end connectors (12) onto the pipe segments.
- 4) Position the valve between the end connectors (fig. 8). Warning: if a high pressure test is required, always position the body with the "REGULAR" label upstream from the fluid direction.
- 5) Fit the union nuts on the valve body and tighten clockwise (fig. 7).
- 6) If necessary, support the pipe with FIP pipe clip model ZIKM and DSM distance plates.

The VEE valve can be equipped with a simple locking device by inserting a lock to protect the system against tampering (fig. 12). The valve body and hub are, in fact, set to house a lockable plate on the valve body using two self-threading screws (see SHE accessories) (fig. 11),

WARNINGS

If volatile liquid such as Hydrogen Peroxide (H₂O₂) or Sodium Hypochlorite (NaClO) are used, for safety reasons we recommend you contact the service centre. These liquids, upon vaporising, could create hazardous over pressures in the area between the body and ball.

Always avoid sudden closing manoeuvres and protect the valve from accidental manoeuvres.

Fig. 9



Fig. 10



Fig. 11



Fig. 12

