



VA DN 15÷50

PVC-U

Air release valve



VA DN 15÷50

The purpose of the VA air release is to eliminate any air entering the pipe with the liquid.

AIR RELEASE VALVE

- Connection system for solvent weld and threaded joints
- **No metal parts in contact with the fluid**
- Can be used as a vacuum breaker valve when installed with the nut at the bottom
- **Valve material compatibility** (PVC-U) with water, drinking water and other food substance conveyance according to **current regulations**
- Can be maintained with the valve body installed

Technical specifications	
Construction	Air release valve
Size range	DN 15 ÷ 50
Nominal pressure	PN 16 with water at 20 °C
Temperature range	0 °C ÷ 60 °C
Coupling standards Reference standards	Solvent welding: EN ISO 1452, EN ISO 15493, BS 4346-1, DIN 8063, NF T54-028. Can be coupled to pipes according to EN ISO 1452, EN ISO 15493, DIN 8062, NF T54-016. Thread: ISO 228-1, DIN 2999. Construction criteria: EN ISO 16137 EN ISO 1452, EN ISO 15493 Test methods and requirements: ISO 9393 Installation criteria: DVS 2204, DVS 2221, UNI 11242
Valve material	PVC-U
Seal material	EPDM

TECHNICAL DATA

PRESSURE VARIATION ACCORDING TO TEMPERATURE

For water and non-hazardous fluids with regard to which the material is classified as CHEMICALLY RESISTANT. In other cases, a reduction of the nominal pressure PN is required (25 years with safety factor).



The information in this leaflet is provided in good faith. No liability will be accepted concerning technical data that is not directly covered by recognised international standards. FIP reserves the right to carry out any modification. Products must be installed and maintained by qualified personnel.

DIMENSIONS

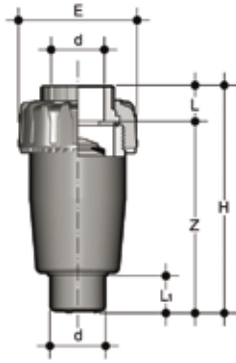

VAIV

Air release valve with male ends for solvent welding, metric series

d	DN	PN	E	H	L	L ₁	Z	g	Code
20	15	16	55	103	16	18	87	105	VAIV020E
25	20	16	66	125	19	20	106	185	VAIV025E
32	25	16	75	150	22	24	128	280	VAIV032E
40	32	16	87	171	26	28	145	415	VAIV040E
50	40	16	100	187	31	34	156	570	VAIV050E
63	50	16	122	223	38	41	185	950	VAIV063E



VAFV

Air release valve with BSP threaded female ends

R	DN	PN	E	H	L	Z	g	Code
1/2"	15	16	55	124	15	94	120	VAFV012E
3/4"	20	16	66	149	16,3	116,4	205	VAFV034E
1"	25	16	75	175	19,1	136,8	360	VAFV100E
1" 1/4	32	16	87	200	21,4	157,2	475	VAFV114E
1" 1/2	40	16	100	209	21,4	166,2	670	VAFV112E
2"	50	16	122	248	25,7	196,6	1130	VAFV200E

COMPONENTS

EXPLODED VIEW

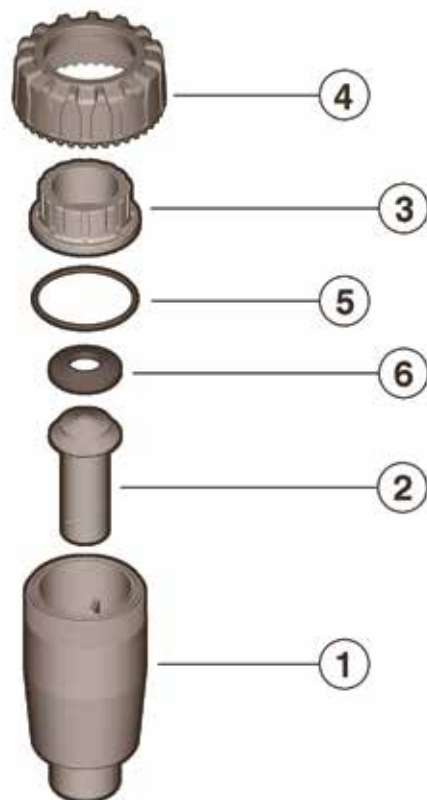

- 1** Body (PVC-U - 1)
- 2** Piston (PVC-U - 1)

- 3** End connector (PVC-U - 1)
- 4** Union nut (PVC-U - 1)

- 5** O-Ring (EPDM - 1)*
- 6** Piston gasket (EPDM - 1)*

* Spare parts
The material of the component and the quantity supplied are indicated between brackets

DISASSEMBLY

- 1) Isolate the valve from the fluid and empty the entire line upstream.
- 2) Unscrew the union nut (4).
- 3) Remove the end connector (3) and O-ring (5).
- 4) Remove the piston (2) and relative seal (6).

ASSEMBLY

- 1) Position the O-ring (5) and piston gasket (6) in their seatings.
- 2) Insert the piston (2) in the body (1).
- 3) Position the end connector (3).
- 4) Tighten the union nut (4).



Note: during assembly operations, it is advisable to lubricate the rubber seals. Mineral oils are not recommended for this task as they react aggressively with EPDM rubber.

INSTALLATION

The FIP air release valve must always be installed in a vertical position with the union nut at the top, as shown in fig.1.

