

VM DN 80÷100

DIAPHRAGM VALVE



VM DN 80÷100

The VM is particularly suitable for shutting off and regulating abrasive or dirty fluids. The handwheel control and diaphragm seal provide precise and effective control, while reducing the risk of water hammer to a minimum.

DIAPHRAGM VALVE

- Connection system for solvent welding and for flanged joints
- **Optimised fluid dynamic design:** maximum output flow rate thanks to the optimised efficiency of the fluid dynamics that characterise the new internal geometry of the body.
- Handwheel that stays at the same height during rotation, with internal bearing to minimise friction and operating torque
- Standard optical indicator
- **Internal operating components in metal** totally isolated from the conveyed fluid
- Bonnet fastening screws in STAINLESS steel protected against the external environment by PE plugs
- **New flanged bodies:** the new bodies, characterised by a monolithic flanged structure, are available in PVC-U, PVC-C, PP-H and PVDF. This design, free from body and flange joints, greatly reduces mechanical stress and increases system performance.

Technical specifications	
Construction	Single wear diaphragm valve
Size range	DN 80 ÷ 100
Nominal pressure	PN 10 with water at 20° C PN 6 with water at 20° C (PTFE version)
Temperature range	0 °C ÷ 100 °C
Coupling standards	Solvent welding: EN ISO 15493, ASTM F 439. Can be coupled to pipes according to EN ISO 15493. Flanging system: ISO 7005-1, EN ISO 15493, EN 558-1, EN1092-1, ANSI B.16.5 cl. 150.
Reference standards	Construction criteria: EN ISO 16138, EN ISO 15493 Test methods and requirements: ISO 9393 Installation criteria: DVS 2204, DVS 2221, UNI 11242
Valve material	Body: PVC-C Bonnet: PP-GR Handwheel PA-GR
Seal material	EPDM, FKM, PTFE (on request NBR)
Control options	Manual control; pneumatic actuator

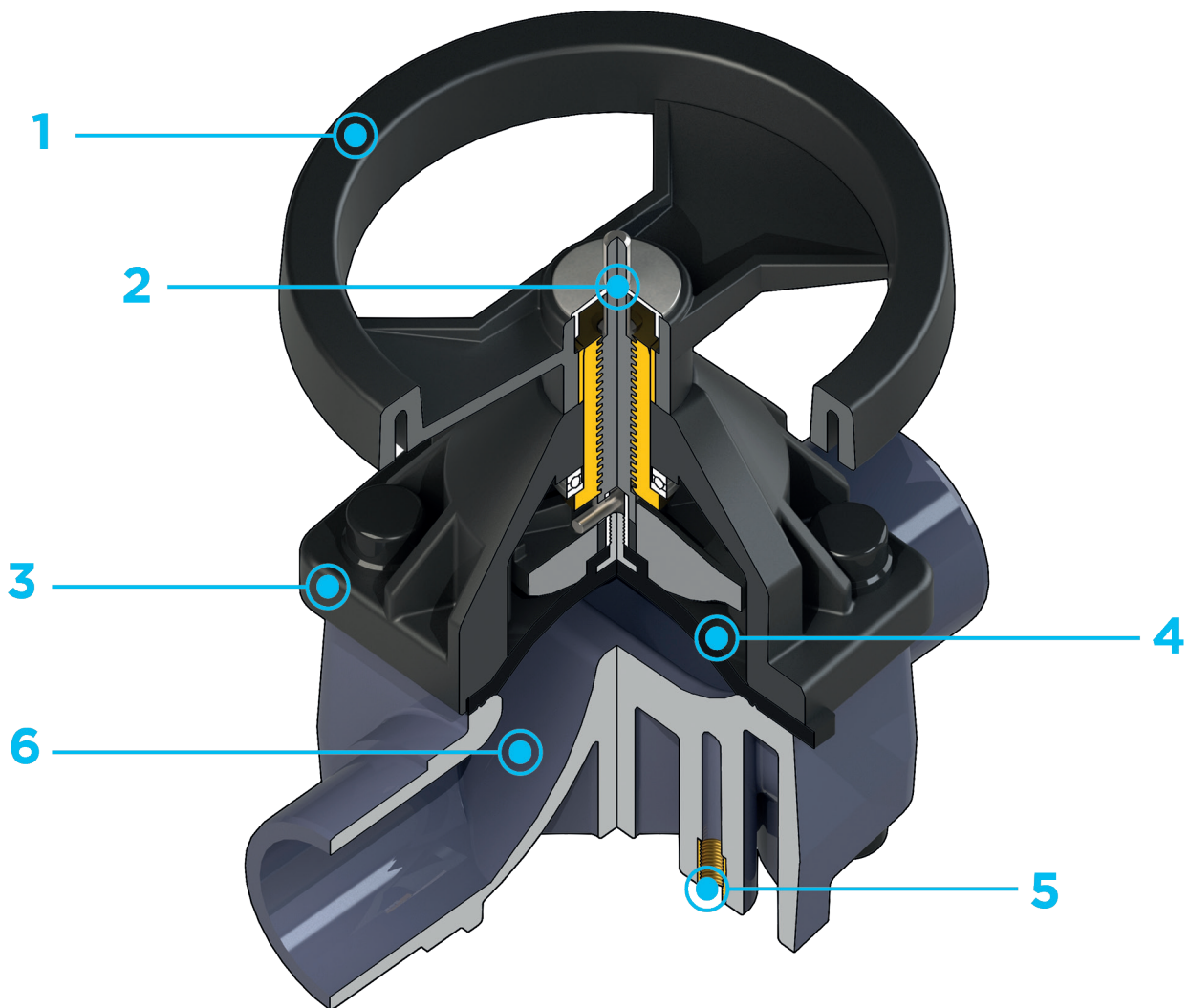

- 1 Handwheel** in (PA-GR) with high mechanical strength and ergonomic **grip for optimum manageability**
- 2 Metal optical position indicator** supplied as standard
- 3 Full protection bonnet** in PP-GR
Internal circular and symmetrical diaphragm sealing area
- 4 Diaphragm** available in EPDM, FPM, PTFE (NBR on request) and easy to replace
- 5 Threaded metal inserts** for anchoring the valve
- 6 New valve body internal design:** substantially higher flow coefficient resulting in lower pressure drops. Optimised adjustment curve for effective and precise flow rate regulation

TECHNICAL DATA

PRESSURE VARIATION ACCORDING TO TEMPERATURE

For water and non-hazardous fluids with regard to which the material is classified as CHEMICALLY RESISTANT. In other cases, a reduction of the nominal pressure PN is required (25 years with safety factor).

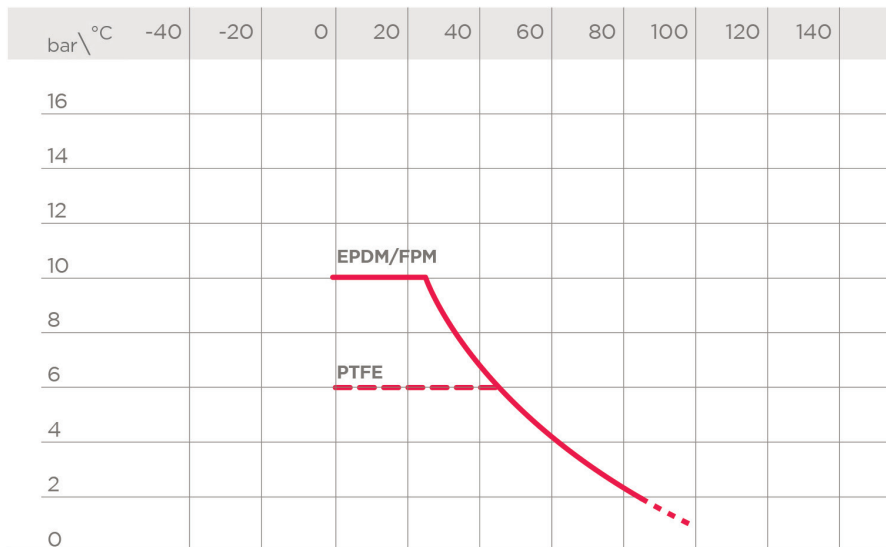

PRESSURE DROP GRAPH

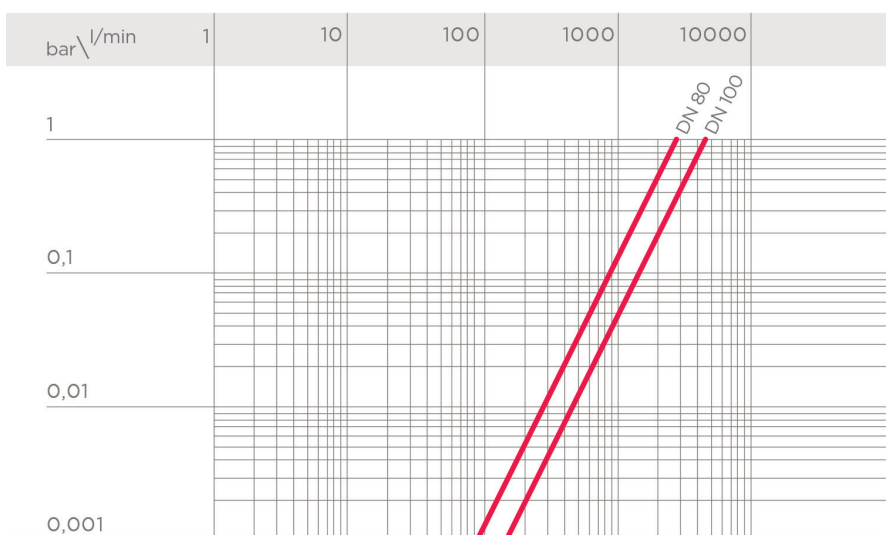

K_v100 FLOW COEFFICIENT

The K_v100 flow coefficient is the Q flow rate of litres per minute of water at a temperature of 20°C that will generate Δp= 1 bar pressure drop at a certain valve position. The Kv100 values shown in the table are calculated with the valve completely open.

DN	80	100
Kv100 l/min	2910	4620

The information in this leaflet is provided in good faith. No liability will be accepted concerning technical data that is not directly covered by recognised international standards. FIP reserves the right to carry out any modification. Products must be installed and maintained by qualified personnel.

DIMENSIONS

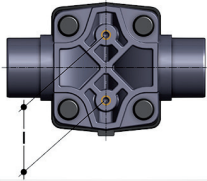
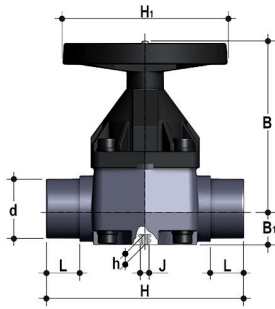

VMDC

Diaphragm valve with male ends for solvent welding, metric series

d	DN	PN	B	B ₁	H	H ₁	h	I	J	L	g	EPDM code	FKM code	PTFE code
90	80	*10	225	55	300	200	23	100	M12	51	7290	VMDC090E	VMDC090F	VMDC090P
110	100	*10	295	69	340	250	23	120	M12	61	10900	VMDC110E	VMDC110F	VMDC110P

*PTFE PN6

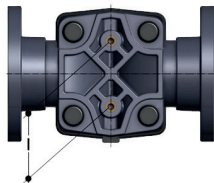
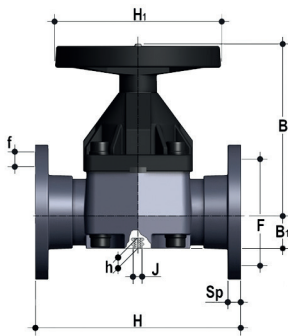

VMOC

Diaphragm valve with flanged monolithic body, drilled EN/ISO/DIN PN10/16. Face to face according to EN 558-1

d	DN	PN	B	B ₁	H	I	H ₁	J	F	f	U	Sp	g	EPDM code	FKM code	PTFE code
90	80	*10	225	64	310	100	200	M12	160	18	8	21,5	9140	VMOC090E	VMOC090F	VMOC090P
110	100	*10	295	72	350	120	250	M12	180	18	8	22,5	13120	VMOC110E	VMOC110F	VMOC110P

*PTFE PN6

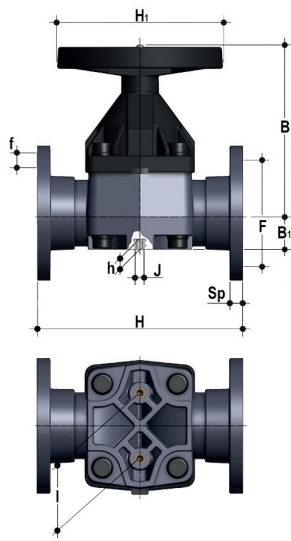

VMOAC

Diaphragm valve with flanged monolithic body, drilled ANSI B16.5 cl.150 #FF

d	PN	B	B ₁	F	f	H	H ₁	I	J	Sp	U	g	EPDM code	FKM code	PTFE code
3"	*10	225	64	152,4	19,1	263	200	100	M12	21,5	4	9140	VMOAC300E	VMOAC300F	VMOAC300P
4"	*10	295	72	190,5	19,1	328	250	120	M12	22,5	8	13120	VMOAC400E	VMOAC400F	VMOAC400P

*PTFE PN6

For installation prior to october 2017 please contact Fip Technical Support

COMPONENTS

EXPLODED VIEW

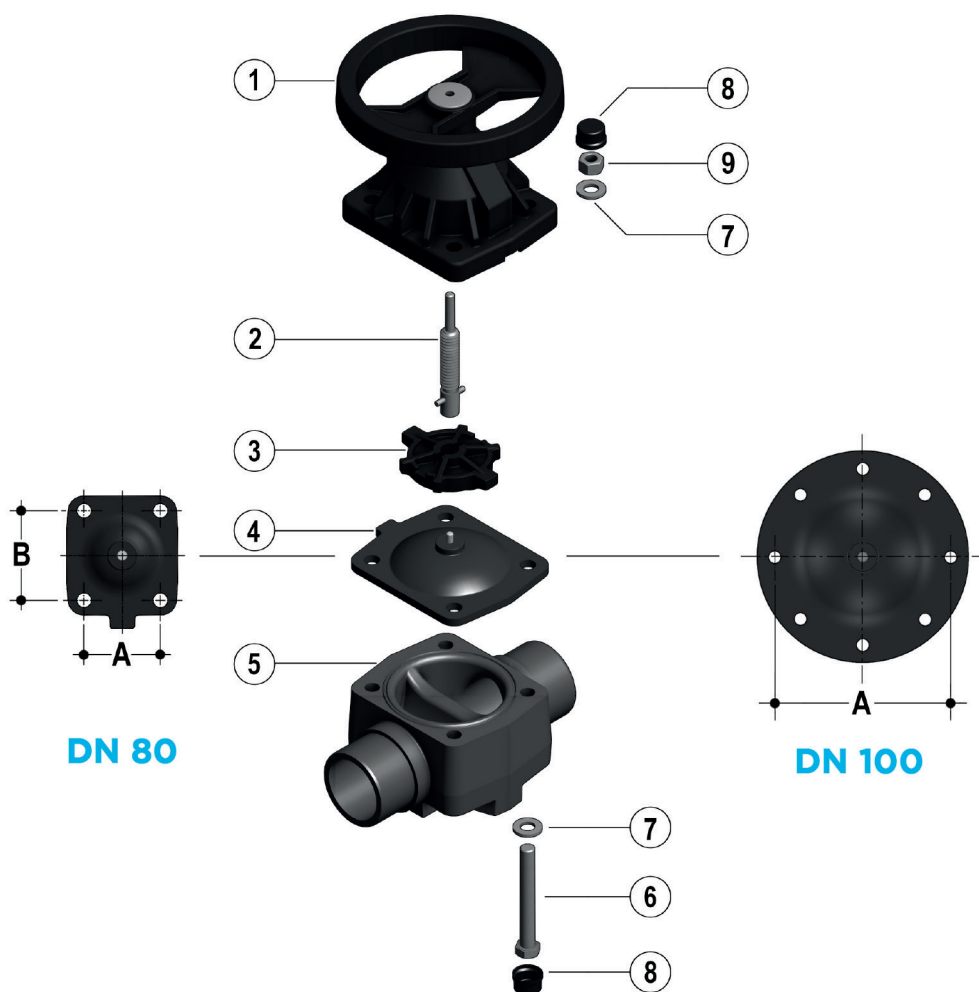

DN	80	100
A	114	193
B	127	-

- | | | |
|--|--|---|
| 1 Bonnet (PP-GR - 1); Handwheel (PA-GR - 1) | 4 Diaphragm seal (EPDM, FKM, PTFE - 1) | 7 Washer (Zinc plated steel - 4) |
| 2 Indicator - stem (STAINLESS steel - 1) | 5 Body (PVC-C - 1) | 8 Protection plug (PE - 4) |
| 3 Shutter (PBT - 1) | 6 Hexagonal screw (Zinc plated steel - 4) | 9 Nut (Zinc plated steel - 4) |

The material of the component and the quantity supplied are indicated in brackets

DISASSEMBLY

The diaphragm constitutes the part of the valve more subject to mechanical and chemical stress from the fluid. Consequently, the condition of the diaphragm must be checked at regular intervals in accordance with the service conditions. To do this, it must be disconnected from the handwheel and from the valve body.

- 1) Cut-off fluid upstream from the valve and make sure it is de-pressurised (downstream drain if necessary).
- 2) Unscrew the four screws (6) and separate the body (5) from the internal components.
- 3) Unscrew the diaphragm (4) from the shutter (3). Rotate the handwheel clockwise to free the stem-shutter unit. Clean or replace the diaphragm, if necessary (4). If necessary, lubricate the stem (2).

ASSEMBLY

- 1) Apply the shutter (3) to the stem (2), ensuring the stem pin is positioned correctly.
- 2) Screw the diaphragm (4) onto the stem (2), taking care not to stretch it.
- 3) Open the valve.
- 4) Place the bonnet-handwheel unit (1) on the body (5) and join the two components with bolts.
- 5) Press the protection plugs into place (8).

INSTALLATION

The valve can be installed in any position and in any direction.
When starting up the plant, make sure that there are no leaks from between the diaphragm and the valve body. If necessary, tighten the fastening screws (6).

WARNINGS

Note: during assembly operations, it is advisable to lubricate the threaded stem. Mineral oils are not recommended for this task as they react aggressively with EPDM rubber.

Moreover, as the diaphragm seal is compressed between the body and the actuator, the valve body stud-bolts and nuts must be checked and tightened, if necessary, prior to installation.