

VKD DN 10÷50

DUAL BLOCK® 2-way ball valve



VKD DN 10÷50

FIP has developed a VKD DUAL BLOCK® 2-WAY ball valve to introduce a high reference standard in thermoplastic valve design. VKD is a True Union ball valve that meets the most stringent needs required by industrial applications.



DUAL BLOCK® 2-WAY BALL VALVE

- Connection system for weld, threaded and flanged joints
- Patented **SEAT STOP®** ball seat carrier system that lets you micro-adjust ball seats and minimise axial force effects
- Easy radial disassembly allowing quick replacement of O-rings and ball seats without any need for tools
- **PN10 True Union valve body** made for PP-H injection moulding equipped with built-in bores for actuation. ISO 9393 compliant test requisites
- Option of disassembling downstream pipes with the valve in the closed position
- Floating **full bore ball** with high surface finish
- **Integrated bracket** for valve anchoring
- Ball seat carriers can be adjusted using the **Easylorque adjustment kit**
- Possibility to have handle with integrated LSQT limit micro switch, even as a retrofit in existing installations

Technical specifications	
Construction	2-way True Union ball valve with locked carrier and lockable union nuts
Size range	DN 10 ÷ 50
Nominal pressure	PN 10 with water at 20° C
Temperature range	0 °C ÷ 95 °C
Coupling standards	Welding: EN ISO 15494 Can be coupled to pipes according to EN ISO 15494 Thread: ISO 228-1, EN 10226-1/2 Flanging system: ISO 7005-1, EN 1092-1, EN ISO 15494, EN 558-1, DIN 2501, ANSI B.16.5 cl. 150
Reference standards	Construction criteria: EN ISO 16135, EN ISO 15494 Test methods and requirements: ISO 9393 Installation criteria: DVS 2202-1, DVS 2207-11, DVS 2208-1, UNI 11318 Actuator couplings: ISO 5211
Valve material	PP-H
Seal material	EPDM, FKM (standard size O-ring); PTFE (ball seats)
Control options	Manual control; electric actuator; pneumatic actuator

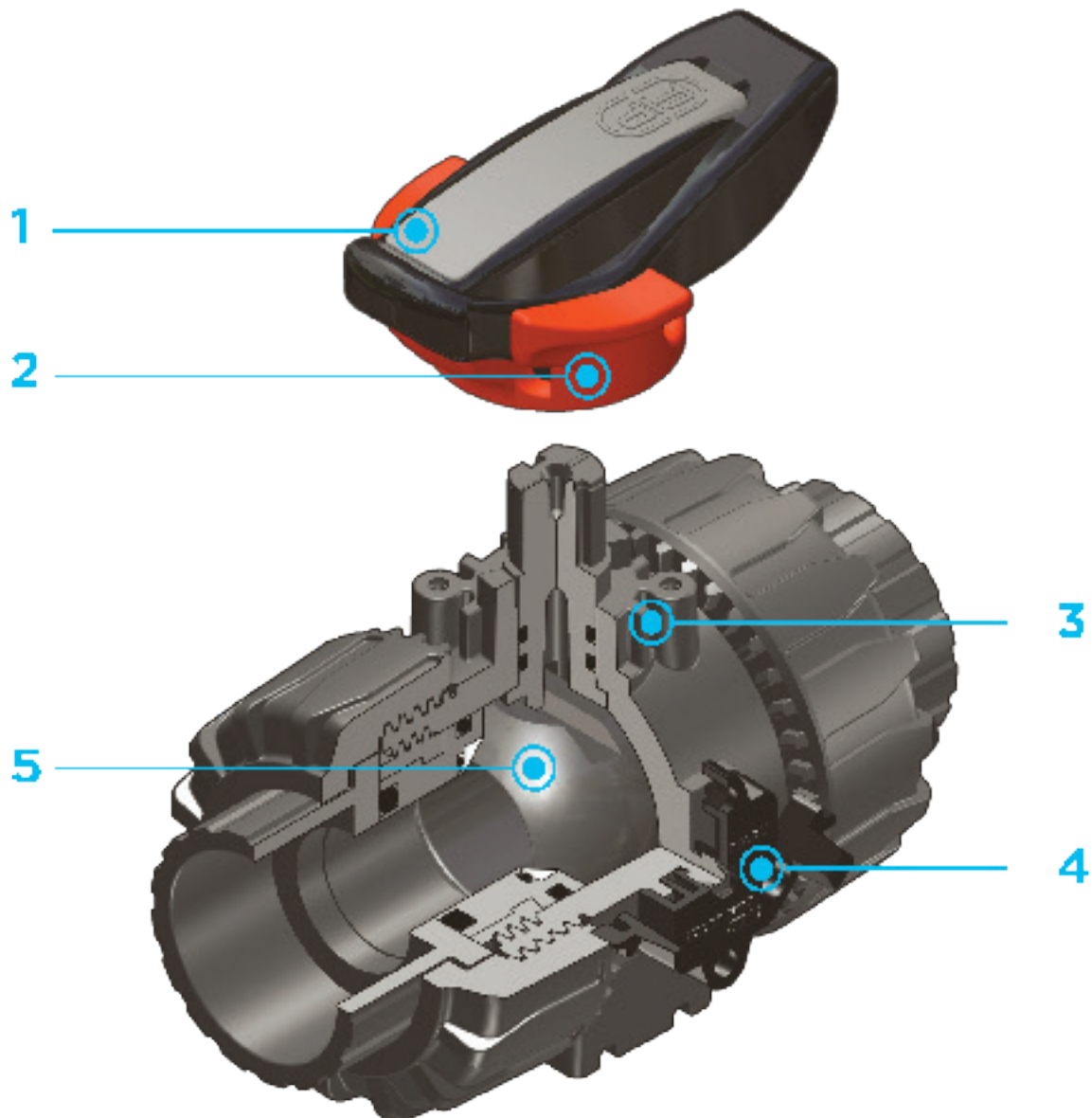

1 Ergonomic HIPVC handle equipped with **removable tool to adjust the ball seat carrier**.

2 **Handle lock 0°- 90° SHKD** (available as an accessory) ergonomically operable during service and padlockable

3 Robust **integrated bracket for valve anchoring**, for easy and quick automation even after valve installation on the system via the Power Quick module (optional)

4 **DUAL BLOCK®** patented lock system that ensures union nut

tightening hold even in severe conditions such as vibrations or heat dilation

5 Machined high surface finish ball that guarantees a smooth operation and increased reliability

TECHNICAL DATA

PRESSURE VARIATION ACCORDING TO TEMPERATURE

Graph valid for water and harmless fluids to which the material is classified as CHEMICALLY RESISTANT. In other cases, a reduction of the nominal PN pressure is required (25 years with safety factor).

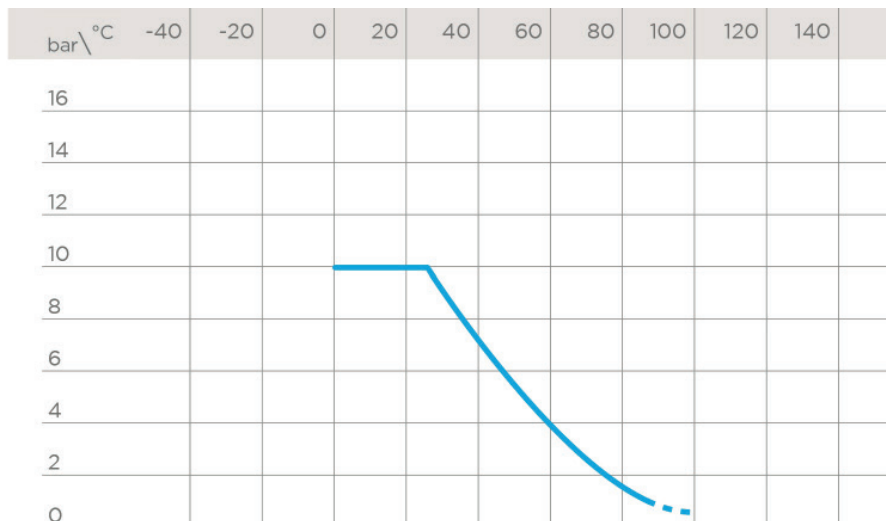

PRESSURE DROP GRAPH

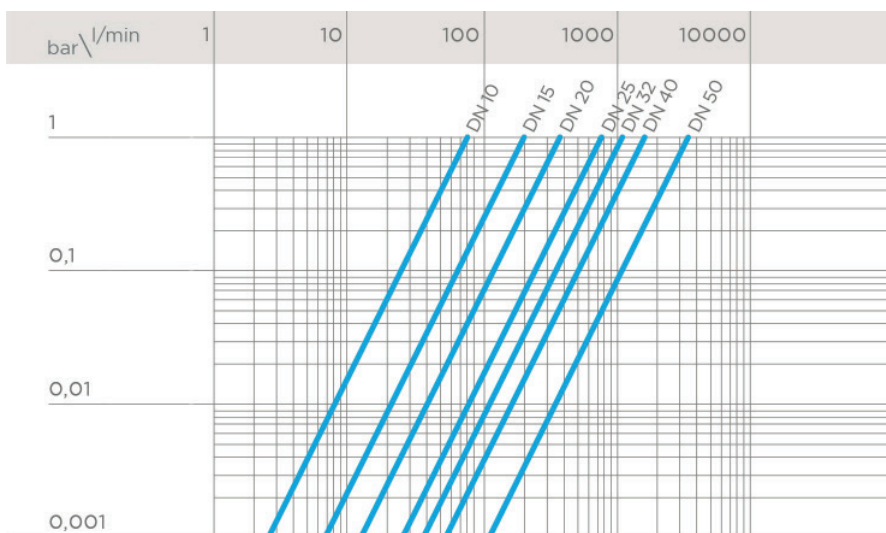

K_v100 FLOW COEFFICIENT

The K_v100 flow coefficient is the Q flow rate of litres per minute of water at a temperature of 20°C that will generate Δp= 1 bar pressure drop at a certain valve position. The Kv100 values shown in the table are calculated with the valve completely open.

DN	10	15	20	25	32	40	50
Kv100 l/min	80	200	385	770	1100	1750	3400

OPERATING TORQUE AT MAXIMUM WORKING PRESSURE

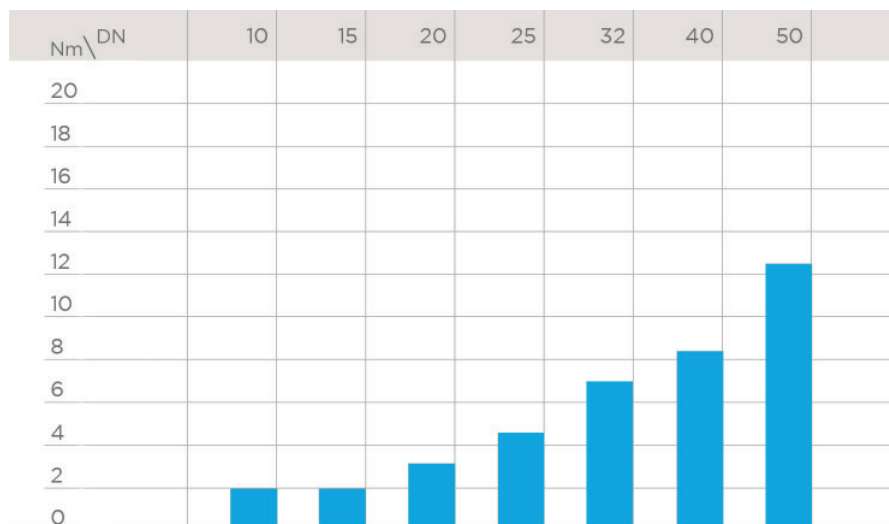

The information in this leaflet is provided in good faith. No liability will be accepted concerning technical data that is not directly covered by recognised international standards. FIP reserves the right to carry out any modification. Products must be installed and maintained by qualified personnel.

DIMENSIONS

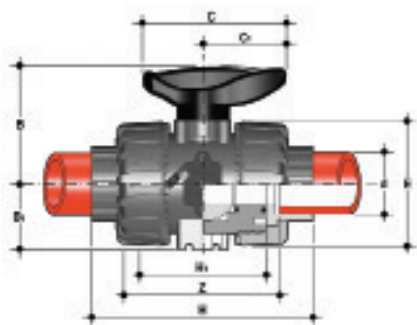

VKDIM

Dual Block® 2-way ball valve with female ends for socket welding, metric series

d	DN	PN	B	B ₁	C	C ₁	E	H	H ₁	Z	g	EPDM code	FKM code
16	10	10	54	29	67	40	54	102	65	74,5	150	VKDIM016E	VKDIM016F
20	15	10	54	29	67	40	54	102	65	73	145	VKDIM020E	VKDIM020F
25	20	10	65	34,5	85	49	65	114	70	82	218	VKDIM025E	VKDIM025F
32	25	10	69,5	39	85	49	73	126	78	90	298	VKDIM032E	VKDIM032F
40	32	10	82,5	46	108	64	86	141	88	100	480	VKDIM040E	VKDIM040F
50	40	10	89	52	108	64	98	164	93	117	682	VKDIM050E	VKDIM050F
63	50	10	108	62	134	76	122	199	111	144	1166	VKDIM063E	VKDIM063F

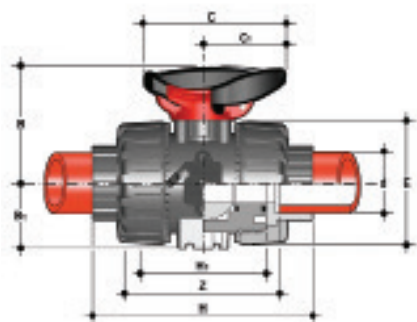

VKDIM/SHX

Dual Block® 2-way ball valve with handle lock and STAINLESS steel threaded inserts with female ends for socket welding, metric series

d	DN	PN	B	B ₁	C	C ₁	E	H	H ₁	Z	g	EPDM code	FKM code
16	10	10	54	29	67	40	54	102	65	74,5	160	VKDIMSHX016E	VKDIMSHX016F
20	15	10	54	29	67	40	54	102	65	73	155	VKDIMSHX020E	VKDIMSHX020F
25	20	10	65	34,5	85	49	65	114	70	82	228	VKDIMSHX025E	VKDIMSHX025F
32	25	10	69,5	39	85	49	73	126	78	90	308	VKDIMSHX032E	VKDIMSHX032F
40	32	10	82,5	46	108	64	86	141	88	100	490	VKDIMSHX040E	VKDIMSHX040F
50	40	10	89	52	108	64	98	164	93	117	692	VKDIMSHX050E	VKDIMSHX050F
63	50	10	108	62	134	76	122	199	111	144	1176	VKDIMSHX063E	VKDIMSHX063F

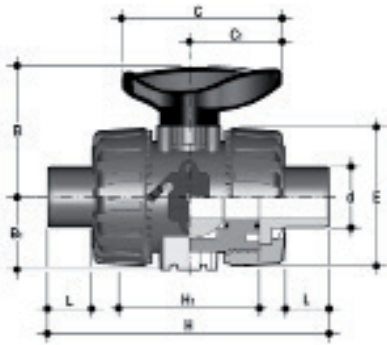

VKDDM

DUAL BLOCK® 2-way ball valve with male ends for socket welding, metric series

d	DN	PN	B	B ₁	C	C ₁	E	H	H ₁	L	g	EPDM code	FKM code
20	15	10	54	29	67	40	54	124	65	16	153	VKDDM020E	VKDDM020F
25	20	10	65	34,5	85	49	65	144	70	18	222	VKDDM025E	VKDDM025F
32	25	10	69,5	39	85	49	73	154	78	20	303	VKDDM032E	VKDDM032F
40	32	10	82,5	46	108	64	86	174	88	22	485	VKDDM040E	VKDDM040F
50	40	10	89	52	108	64	98	194	93	23	672	VKDDM050E	VKDDM050F
63	50	10	108	62	134	76	122	224	111	29	1176	VKDDM063E	VKDDM063F

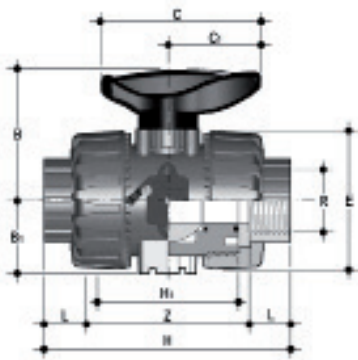

VKDFM

Dual Block® 2-way ball valve with BSP threaded female ends

R	DN	PN	B	B ₁	C	C ₁	E	H	H ₁	L	Z	g	EPDM code	FKM code
1/2"	15	10	54	29	67	40	54	110	65	15	80	145	VKDFM012E	VKDFM012F
3/4"	20	10	65	34,5	85	49	65	116	70	16	83	220	VKDFM034E	VKDFM034F
1"	25	10	69,5	39	85	49	73	134	78	19	96	298	VKDFM100E	VKDFM100F
1" 1/4	32	10	82,5	46	108	64	86	153	88	21	110	488	VKDFM114E	VKDFM114F
1" 1/2	40	10	89	52	108	64	98	156	93	21	113	682	VKDFM112E	VKDFM112F
2"	50	10	108	62	134	76	122	186	111	26	135	1181	VKDFM200E	VKDFM200F

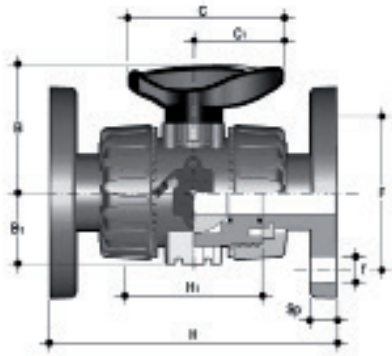

VKDOM

DUAL BLOCK® 2-way ball valve with fixed flanges, drilled EN/ISO/DIN PN 10/16. Face to face according to EN 558-1

d	DN	PN	B	B ₁	C	C ₁	F	f	H	H ₁	Sp	U	g	EPDM code	FKM code
20	15	10	54	29	67	40	65	14	130	65	11	4	387	VKDOM020E	VKDOM020F
25	20	10	65	34,5	85	49	75	14	150	70	14	4	504	VKDOM025E	VKDOM025F
32	25	10	69,5	39	85	49	85	14	160	78	14	4	697	VKDOM032E	VKDOM032F
40	32	10	82,5	46	108	64	100	18	180	88	14	4	1075	VKDOM040E	VKDOM040F
50	40	10	89	52	108	64	110	18	200	93	16	4	1346	VKDOM050E	VKDOM050F
63	50	10	108	62	134	76	125	18	230	111	16	4	2060	VKDOM063E	VKDOM063F

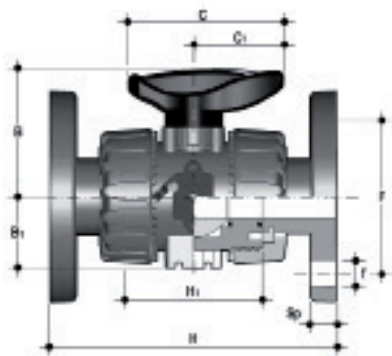

VKDOAM

DUAL BLOCK® 2-way ball valve with fixed flange, drilled ANSI B16.5 cl.150#FF

d	DN	PN	B	B ₁	C	C ₁	F	f	H	H ₁	Sp	U	g	EPDM code	FKM code
1/2"	15	10	54	29	67	40	60,3	15,9	143	65	11	4	387	VKDOAM012E	VKDOAM012F
3/4"	20	10	65	34,5	85	49	69,9	15,9	172	70	14	4	504	VKDOAM034E	VKDOAM034F
1"	25	10	69,5	39	85	49	79,4	15,9	187	78	14	4	697	VKDOAM100E	VKDOAM100F
1" 1/4	32	10	82,5	46	108	64	88,9	15,9	190	88	14	4	1075	VKDOAM114E	VKDOAM114F
1" 1/2	40	10	89	52	108	64	98,4	15,9	212	93	16	4	1346	VKDOAM112E	VKDOAM112F
2"	50	10	108	62	134	76	120,7	19,1	234	111	16	4	2060	VKDOAM200E	VKDOAM200F

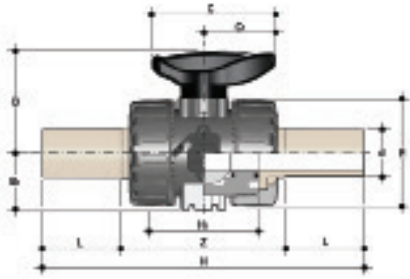

VKDBM

DUAL BLOCK® 2-way ball valve with long spigot male ends in PP-H SDR 11 for butt welding or electrofusion (CVDM)

d	DN	PN	B	B ₁	C	C ₁	E	H	H ₁	L	Z	g	EPDM code	FKM code
20	15	10	54	29	67	40	54	175	65	40,5	94	220	VKDBM020E	VKDBM020F
25	20	10	65	35	85	49	65	212	70	54	106	340	VKDBM025E	VKDBM025F
32	25	10	70	39	85	49	73	226	78	56	117	443	VKDBM032E	VKDBM032F
40	32	10	83	46	108	64	86	246	88	56	131	593	VKDBM040E	VKDBM040F
50	40	10	89	52	108	64	98	271	93	60,5	145	945	VKDBM050E	VKDBM050F
63	50	10	108	62	134	76	122	300	111	65,5	161	1607	VKDBM063E	VKDBM063F

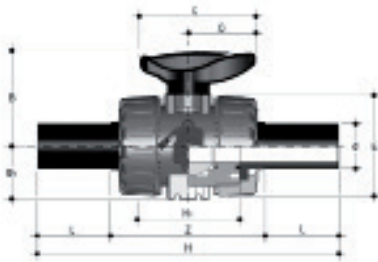

VKDBEM

DUAL BLOCK® 2-way ball valve with PE100 SDR 11 male end connectors for butt welding or electrofusion (CVDE)

d	DN	PN	B	B ₁	C	C ₁	E	H	H ₁	L	Z	g	EPDM code	FKM code
20	15	10	54	29	67	40	54	175	65	40,5	94	210	VKDBEM020E	VKDBEM020F
25	20	10	65	34,5	85	49	65	213	70	54	106	325	VKDBEM025E	VKDBEM025F
32	25	10	69,5	39	85	49	73	228	78	56	117	420	VKDBEM032E	VKDBEM032F
40	32	10	82,5	46	108	64	86	247	88	56	131	570	VKDBEM040E	VKDBEM040F
50	40	10	89	52	108	64	98	271	93	60,5	145	900	VKDBEM050E	VKDBEM050F
63	50	10	108	62	134	76	122	300	111	65,5	161	1500	VKDBEM063E	VKDBEM063F

ACCESSORIES

CVDM

End connectors in PP-H SDR 11 PN 10, long spigot, for butt welding

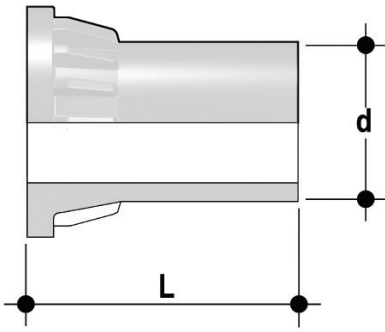

d	DN	PN	L	SDR	Code
20	15	10	55	11	CVDM11020
25	20	10	70	11	CVDM11025
32	25	10	74	11	CVDM11032
40	32	10	78	11	CVDM11040
50	40	10	84	11	CVDM11050
63	50	10	91	11	CVDM11063

CVDE

Long spigot PE100 end connectors for joints with electrofusion fittings or for butt welding

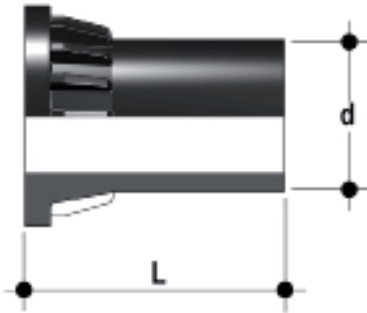

d	DN	PN	L	SDR	Code
20	15	16	55	11	CVDE11020
25	20	16	70	11	CVDE11025
32	25	16	74	11	CVDE11032
40	32	16	78	11	CVDE11040
50	40	16	84	11	CVDE11050
63	50	16	91	11	CVDE11063

SHKD

Handle block kit 0° - 90° lockable



d	DN	Code
16 - 20	10 - 15	SHKD020
25 - 32	20 - 25	SHKD032
40 - 50	32 - 40	SHKD050
63	50	SHKD063

PMKD

Wall mounting plate

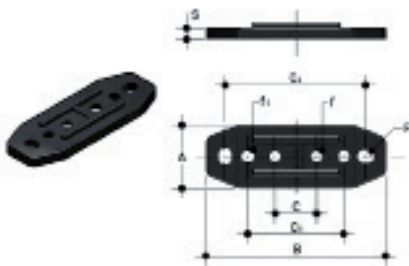

d	DN	A	B	C	C ₁	C ₂	F	f	f ₁	S	Code
16	10	30	86	20	46	67,5	6,5	5,3	5,5	5	PMKD1
20	15	30	86	20	46	67,5	6,5	5,3	5,5	5	PMKD1
25	20	30	86	20	46	67,5	6,5	5,3	5,5	5	PMKD1
32	25	30	86	20	46	67,5	6,5	5,3	5,5	5	PMKD1
40	32	40	122	30	72	102	6,5	6,3	6,5	6	PMKD2
50	40	40	122	30	72	102	6,5	6,3	6,5	6	PMKD2
63	50	40	122	30	72	102	6,5	6,3	6,5	6	PMKD2

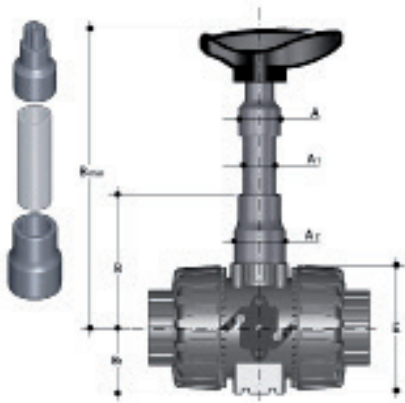

PSKD

Stem extension

d	DN	A	A ₁	A ₂	E	B	B ₁	B _{min}	Code
16	10	32	25	32	54	70	29	139,5	PSKD020
20	15	32	25	32	54	70	29	139,5	PSKD020
25	20	32	25	40	65	89	34,5	164,5	PSKD025
32	25	32	25	40	73	93,5	39	169	PSKD032
40	32	40	32	50	86	110	46	200	PSKD040
50	40	40	32	50	98	116	52	206	PSKD050
63	50	40	32	59	122	122	62	225	PSKD063



Easytorque Kit

Kit for ball seat carrier tightening adjustment for DUAL BLOCK® DN 10-50 series valves

d	DN	Tightening torque recommended*	Code
3/8"-1/2"	10-15	3 N m - 2,21 Lbf ft	KET01
3/4"	20	4 N m - 2,95 Lbf ft	KET01
1"	25	5 N m - 3,69 Lbf ft	KET01
1" 1/4	32	5 N m - 3,69 Lbf ft	KET01
1" 1/2	40	7 N m - 5,16 Lbf ft	KET01
2"	50	9 N m - 6,64 Lbf ft	KET01

*calculated in ideal installation conditions

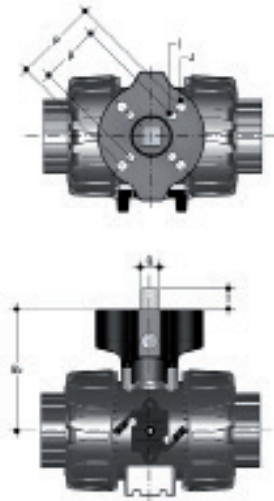

Power Quick/CP

The valve can be equipped with pneumatic actuators, using the PP-GR module reproducing the drilling pattern foreseen by ISO 5211

d	DN	B ₁	Q	T	p x j	P x J	Code
16	10	58	11	12	F03 x 5,5	F04 x 5,5	PQCP020
20	15	58	11	12	F03 x 5,5	F04 x 5,5	PQCP020
25	20	69	11	12	*F03 x 5,5	F05 x 6,5	PQCP025
32	25	74	11	12	*F03 x 5,5	F05 x 6,5	PQCP032
40	32	91	14	16	F05 x 6,5	F07 x 8,5	PQCP040
50	40	97	14	16	F05 x 6,5	F07 x 8,5	PQCP050
63	50	114	14	16	F05 x 6,5	F07 x 8,5	PQCP063

*F04 x 5.5 on request

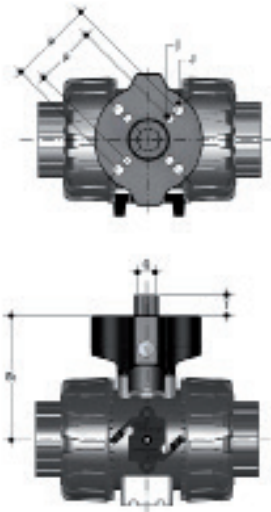

Power Quick/CE

The valve can be equipped with electric actuators, using the PP-GR module reproducing the drilling pattern foreseen by ISO 5211

d	DN	B ₂	Q	T	p x j	P x J	Code
16	10	58	14	16	F03 x 5,5	F04 x 5,5	PQCE020
20	15	58	14	16	F03 x 5,5	F04 x 5,5	PQCE020
25	20	69	14	16	*F03 x 5,5	F05 x 6,5	PQCE025
32	25	74	14	16	*F03 x 5,5	F05 x 6,5	PQCE032
40	32	91	14	16	F05 x 6,5	F07 x 8,5	PQCE040
50	40	97	14	16	F05 x 6,5	F07 x 8,5	PQCE050
63	50	114	14	16	F05 x 6,5	F07 x 8,5	PQCE063

*F04 x 5.5 on request

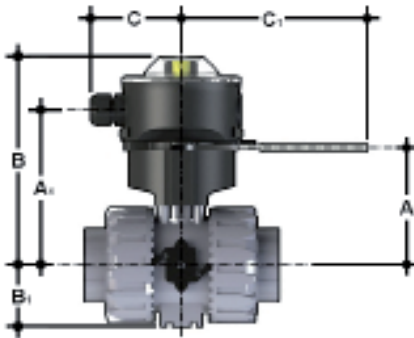

LS Quick Kit

The Limit Switch Quick Kit allows the fast and secure installation of the FIP LSQT to the VKD valves. The body is in PP-GR and the handle is in stainless steel AISI 316. The handle block at 0° and 90° is also available by default (hole diameter 6.5 mm). The kit can be assembled on the valve even if already installed on the system. For technical data of the LSQT box see FIP actuated valves catalogue.

d	DN	A	A ₁	B	B ₁	C	C ₁	Code
16	10	60	91,5	137	29	76,5	157,5	LSQKIT20
20	15	60	91,5	137	29	76,5	157,5	LSQKIT20
25	20	71	102,5	148	34,5	76,5	157,5	LSQKIT25
32	25	76	107,5	153	39	76,5	157,5	LSQKIT32
40	32	93	124,5	170	46	76,5	157,5	LSQKIT40
50	40	99	130,5	176	52	76,5	157,5	LSQKIT50
63	50	116	147,5	193	62	76,5	157,5	LSQKIT63

FASTENING AND SUPPORTING



All valves, whether manual or actuated, must be adequately supported in many applications. The VKD valve series is therefore ready to be equipped with threaded supporting brackets (optional) that permits direct anchoring of the valve body without the need of other components. For wall installation, dedicated PMKD mounting plates which are available as accessories can be used. These plates should be fastened to the valve before wall installation. PMKD plates also allow VKD valve alignment with FIP ZIKM pipe clips as well as allowing different sizes of valves to be aligned.

d	DN	g	H	L	J*
16	10	31,5	27	20	M4 x 6
20	15	31,5	27	20	M4 x 6
25	20	40	30	20	M4 x 6
32	25	40	30	20	M4 x 6
40	32	50	35	30	M6 x 10
50	40	50	35	30	M6 x 10
63	50	60	40	30	M6 x 10

* With threaded inserts

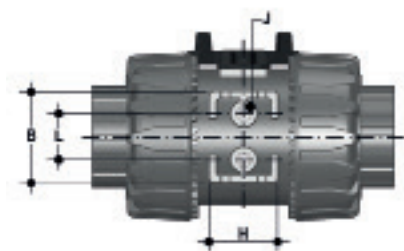

COMPONENTS

EXPLODED VIEW

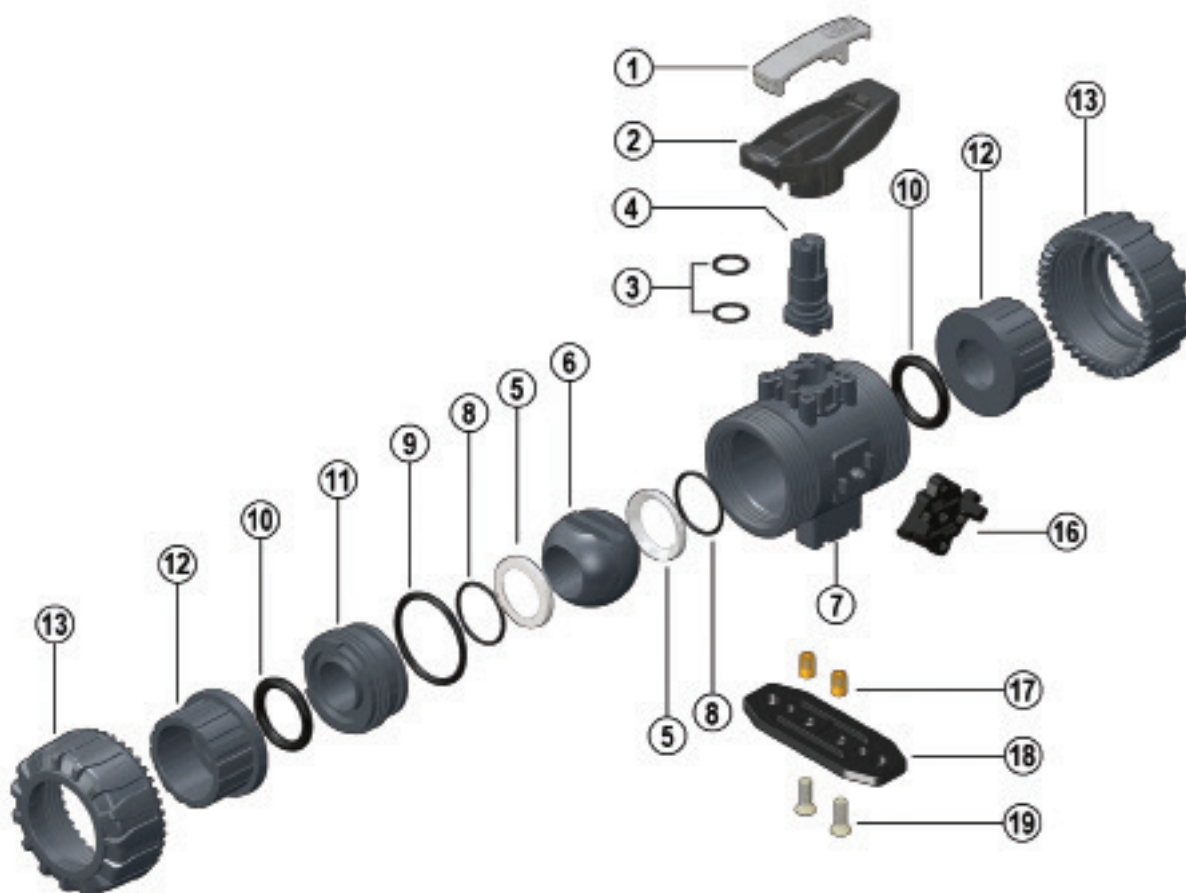

- | | | | | | |
|----------|--------------------------------|-----------|---------------------------------------|-----------|---|
| 1 | Handle insert (PVC - 1) | 8 | Ball seat O-Rings (EPDM or FKM - 2)* | 14 | Spring (STAINLESS steel - 1)** |
| 2 | Handle (HIPVC - 1) | 9 | Radial seal O-Ring (EPDM or FKM - 1)* | 15 | Handle safety block (PP-GR - 1)** |
| 3 | Stem O-rings (EPDM o FKM - 2)* | 10 | Socket seal O-Ring (EPDM or FKM - 2)* | 16 | DUAL BLOCK® (POM - 1) |
| 4 | Stem (PP-H - 1) | 11 | Ball seat carrier (PP-H - 1) | 17 | Threaded inserts (STAINLESS steel or Brass - 2)** |
| 5 | Ball seat (PTFE - 2)* | 12 | End connector (PP-H - 2)* | 18 | Distance plate (PP-GR - 1)** |
| 6 | Ball (PP-H - 1) | 13 | Union nut (PP-H - 2) | 19 | Screw (STAINLESS steel - 2)** |
| 7 | Body (PP-H - 1) | | | | |

* Spare parts

** Accessories

The component material and quantity supplied are indicated in the parentheses.

DISASSEMBLY

- 1) Isolate the valve from the line (release the pressure and empty the pipeline).
- 2) Unlock the union nuts by pressing the lever on the DUAL BLOCK® (16) along the axis and separate it from the union nut (fig. 1-2). It is also possible to completely remove the block device from the body of the valve.
- 3) Fully unscrew the union nuts (13) and extract the body sideways.
- 4) Before dismounting, hold the valve in a vertical position and open it 45° to drain any liquid that might remain.
- 5) After closing the valve, remove the special insert (1) from the handle (2) and push the two projecting ends into the corresponding recesses on the ball seat carrier (11). Rotate the stop ring anti-clockwise to extract it (fig. 3-4).
- 6) Pull the handle (2) upwards to remove it from the valve stem (4).
- 7) Press on the ball from the side opposite the "REGULAR - ADJUST" label, being sure not to scratch it, until the ball seat carrier exits (11), then extract the ball (6).
- 8) Press the stem (4) inwards until it exits the body.
- 9) Remove the O-Ring (3, 8, 9, 10) and PTFE ball seats (5) extracting them from their grooves, as illustrated in the exploded view.

ASSEMBLY

- 1) All the O-rings (3, 8, 9, 10) must be inserted in their grooves as shown in the exploded view.
- 2) Insert the stem (4) from inside the valve body (7).
- 3) Place the PTFE ball seats (5) in the housings in the body (7) and in the ball seat ball seat carrier (11).
- 4) Insert the ball (6) rotating it to the closed position.
- 5) Screw the carrier (11) into the body and tighten up in the clockwise direction using the handle (2) to limit stop.
- 6) Insert the valve between the end connectors (12) and tighten the union nuts (13) making sure that the socket seal O-rings (10) do not exit their seats.
- 7) The handle (2) should be placed on the valve stem (4).



Note: during assembly operations, it is advisable to lubricate the rubber seals. Mineral oils are not recommended for this task as they react aggressively with EPDM rubber.

Fig. 1



Fig. 2



Fig. 3



Fig. 4



INSTALLATION

Before proceeding with installation, please follow these instructions carefully:

- 1) Check that the pipes to be connected to the valve are aligned in order to avoid mechanical stress on the threaded joints.
- 2) Check that the DUAL BLOCK® union nut locking device (16) is fitted to the valve body.
- 3) To release the union nuts, axially press the release lever to separate the lock and then unscrew it in the counter-clockwise direction.
- 4) Unscrew the union nuts (13) and insert them on the pipe segments.
- 5) Solvent weld or screw the end connectors (12) onto the pipe ends.
- 6) Position the valve body between the end connectors and fully tighten the union nuts (13) manually by rotating clockwise without using wrenches or other tools that could damage the union nut surface.
- 7) Lock the union nuts by returning the DUAL BLOCK® to its housing, pressing on it until the hinges lock on the union nuts.
- 8) If necessary, support the pipework with FIP pipe clips or by means of the carrier built into the valve itself (see paragraph "fastening and carriers").

The VKD valve can be equipped with a handle lock to prevent ball rotation (supplied separately).

When the handle safety block (14, 15) is installed, lift the lever (15) and rotate the handle (fig. 6-7).

A lock can also be installed on the handle to protect the system against tampering (fig. 8).

Seal can be adjusted using the extractable insert on the handle (fig. 3-4).

The seals can be adjusted later with the valve installed on the pipe by simply tightening the union nuts. This "micro adjustment", only possible with FIP valves thanks to the patented "Seat stop system", allows the seal to be recovered where PTFE ball seats are worn due to a high number of operations. The Easytorque kit can also be used for micro adjustments (fig. 5).

WARNINGS

- If volatile liquid such as Hydrogen Peroxide (H₂O₂) or Sodium Hypochlorite (NaClO) are used, for safety reasons we recommend you contact the service centre. These liquids, upon vaporising, could create hazardous over pressures in the area between the body and ball.
- Always avoid sudden closing operations and protect the valve from accidental operations.

Fig.5



Fig.6



Fig.7

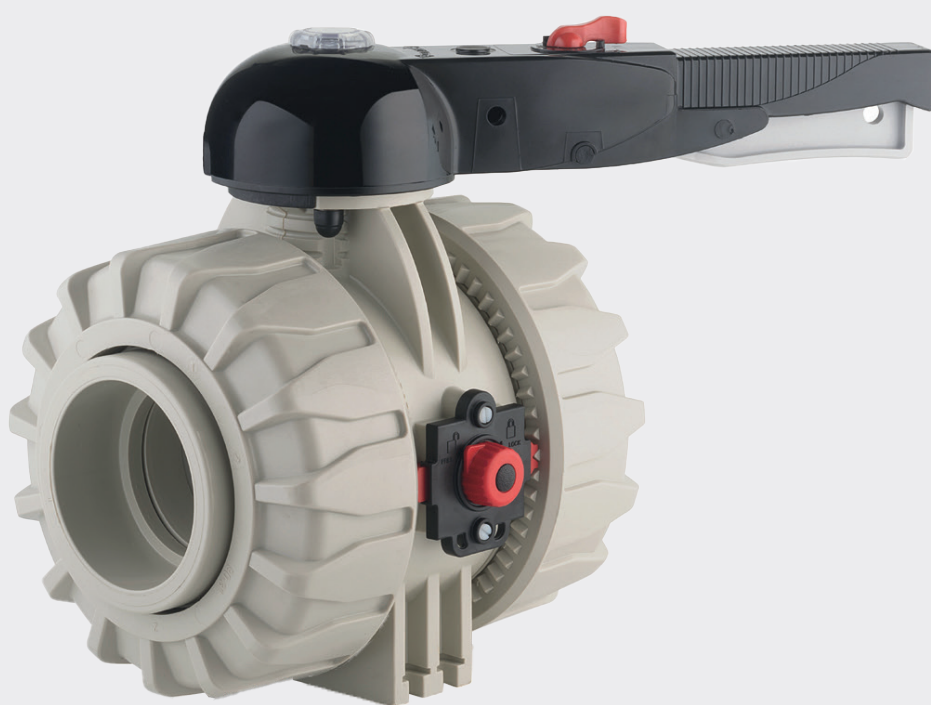

Fig.8



VKD DN 65÷100

DUAL BLOCK® 2-way ball valve



VKD DN 65÷100

FIP has developed a VKD DUAL BLOCK® ball valve to introduce a high reference standard in thermoplastic valve design. VKD is a True Union ball valve that meets the most stringent needs required by industrial applications. This valve is also equipped with a customisable Labelling System.



DUAL BLOCK® 2-WAY BALL VALVE

- Connection system for weld, threaded and flanged joints
- Patented **SEAT STOP®** ball seat carrier system that lets you micro-adjust ball seats and minimise axial force effects
- Easy radial disassembly allowing quick replacement of O-rings and ball seats without any need for tools
- **PN10 True Union valve body** made for PP-H injection moulding equipped with built-in bores for actuation. ISO 9393 compliant test requisites
- Option of disassembling downstream pipes with the valve in the closed position
- **Full bore ball** with high surface finish
- **Integrated bracket** for valve anchoring
- Possibility of installing a gear box or pneumatic and/or electric actuators by applying an ISO standard bore PP-GR flange
- **STAINLESS steel co-moulded stem**, with square section as per ISO 5211
- Possibility to have handle with integrated LSQT limit micro switch, even as a retrofit in existing installations

Technical specifications

Construction	2-way True Union ball valve with locked carrier and union nuts
Size range	DN 65 ÷ 100
Nominal pressure	PN 10 with water at 20° C
Temperature range	0 °C ÷ 95 °C
Coupling standards	<p>Welding: EN ISO 15494. Can be coupled to pipes according to EN ISO 15494</p> <p>Thread: ISO 228-1, EN 10226-1/2</p> <p>Flanging system: ISO 7005-1, EN ISO 1092-1, EN ISO 15494 EN 558-1, DIN 2501, ANSI B.16.5 cl.150</p>
Reference standards	<p>Construction criteria: EN ISO 16135, EN ISO 15494</p> <p>Test methods and requirements: ISO 9393</p> <p>Installation criteria: DVS 2202-1, DVS 2207-11, DVS 2208-1, UNI 11318</p> <p>Actuator couplings: ISO 5211</p>
Valve material	PP-H
Seal material	EPDM, FKM; PTFE (ball seats)
Control options	Manual control; electric actuator; pneumatic actuator

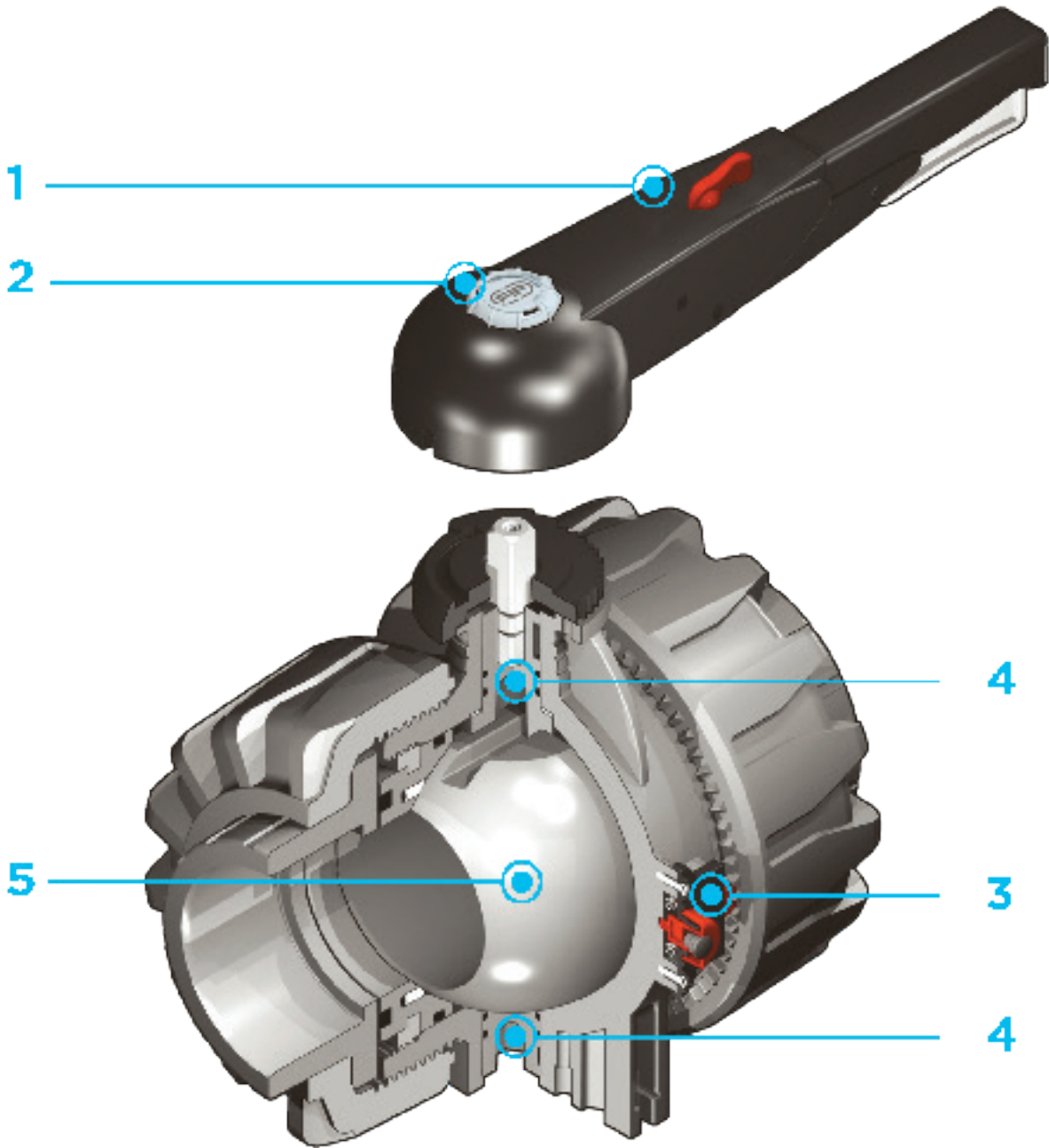

1 HIPVC ergonomic multifunctional handle for quick operation, **lock and graduated adjustment in 10 positions**. Possibility of inhibiting rotation with a lock

2 Customisable Labelling System: LCE module made of a transparent protection plug and **customisable tag holder** using the LSE set

(available as accessory). The customisation lets you identify the valve on the system according to specific needs

3 **DUAL BLOCK®** patented lock system that ensures union nut tightening hold even in severe conditions such as vibrations or heat dilation

4 **Double stem** with double O-Rings for ball centring and operating torque reduction

5 Machined high surface finish ball that guarantees a smooth operation and increased reliability

TECHNICAL DATA

PRESSURE VARIATION ACCORDING TO TEMPERATURE

Graph valid for water and harmless fluids to which the material is classified as CHEMICALLY RESISTANT. In other cases, a reduction of the nominal PN pressure is required (25 years with safety factor).

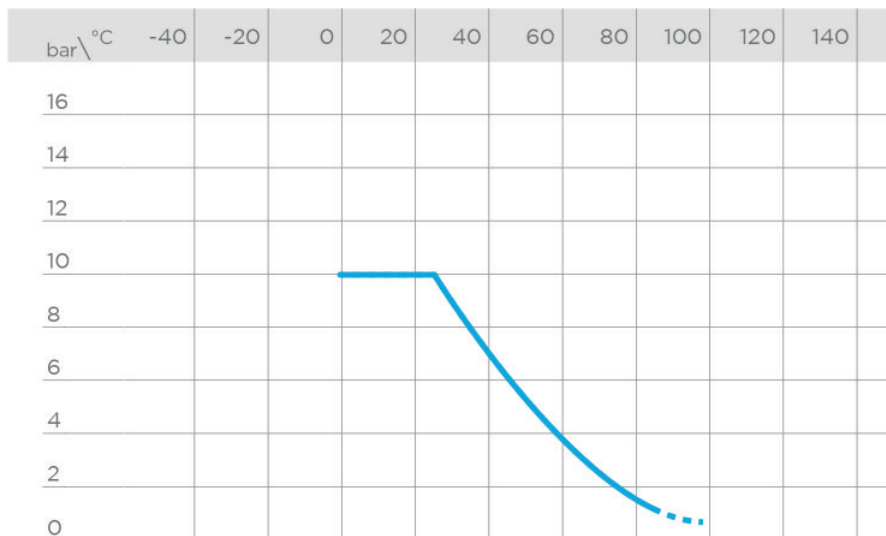

PRESSURE DROP GRAPH

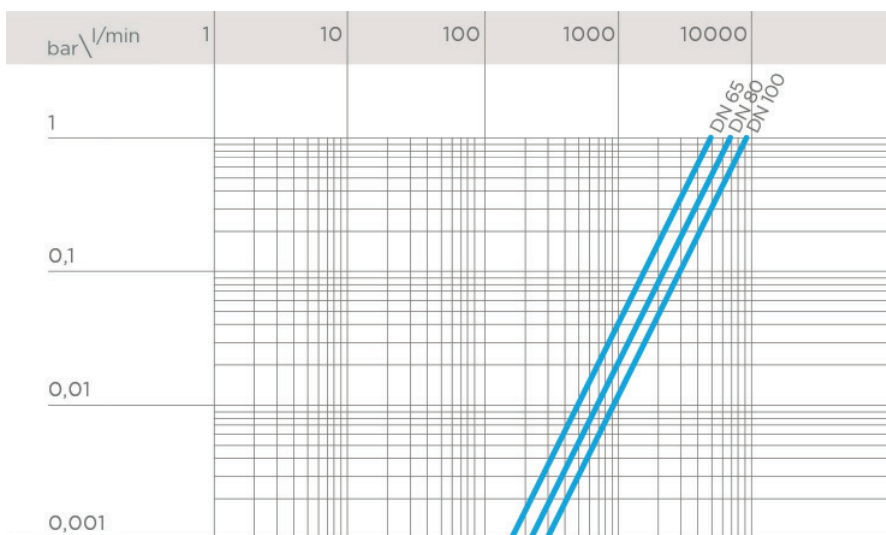

K_v100 FLOW COEFFICIENT

The K_v100 flow coefficient is the Q flow rate of litres per minute of water at a temperature of 20°C that will generate Δp= 1 bar pressure drop at a certain valve position. The K_v100 values shown in the table are calculated with the valve completely open.

DN	65	80	100
K _v 100 l/min	5250	7100	9500

OPERATING TORQUE AT MAXIMUM WORKING PRESSURE

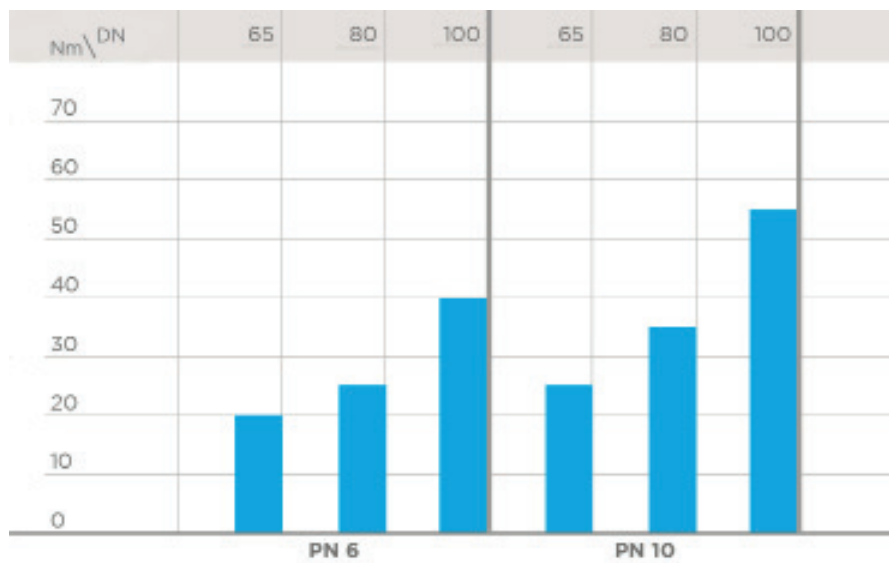

The information in this leaflet is provided in good faith. No liability will be accepted concerning technical data that is not directly covered by recognised international standards. FIP reserves the right to carry out any modification. Products must be installed and maintained by qualified personnel.

DIMENSIONS

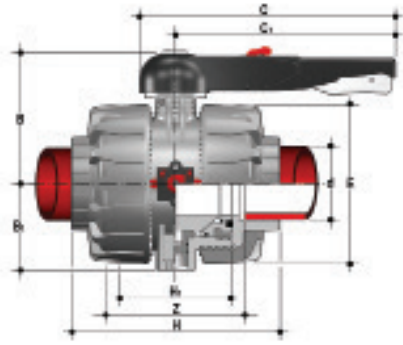

VKDIM

DUAL BLOCK® 2-way ball valve with female ends for socket welding, metric series

d	DN	PN	B	B ₁	C	C ₁	E	H	H ₁	L	Z	g	EPDM code	FKM code
75	65	10	164	87	225	175	162	213	133	30	153	3090	VKDIM075E	VKDIM075F
90	80	10	177	105	327	272	202	239	149	33	173	5080	VKDIM090E	VKDIM090F
110	100	10	195	129	385	330	236	268	167	34,5	199	7725	VKDIM110E	VKDIM110F

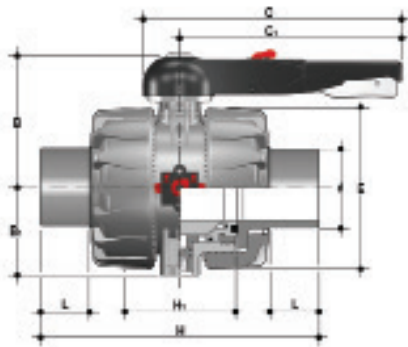

VKDDM

DUAL BLOCK® 2-way ball valve with male ends for socket welding, metric series

d	DN	PN	B	B ₁	C	C ₁	E	H	H ₁	L	g	EPDM code	FKM code
75	65	10	164	87	225	175	162	284	133	44	3190	VKDDM075E	VKDDM075F
90	80	10	177	105	327	272	202	300	149	51	5280	VKDDM090E	VKDDM090F
110	100	10	195	129	385	330	236	340	167	61	8010	VKDDM110E	VKDDM110F

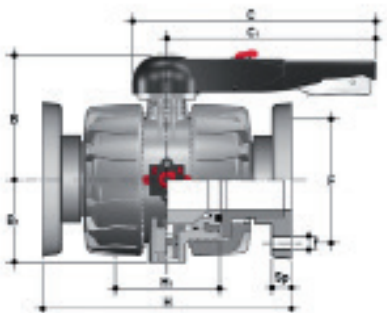

VKDOM

DUAL BLOCK® 2-way ball valve with fixed flanges, drilled EN/ISO/DIN PN10/16. Face to face according to EN 558-1

d	DN	PN	B	B ₁	C	C ₁	F	f	H	H ₁	Sp	U	g	EPDM code	FKM code
75	65	10	164	87	225	175	145	17	290	133	24	4	4500	VKDOM075E	VKDOM075F
90	80	10	177	105	327	272	160	17	310	149	25	8	6455	VKDOM090E	VKDOM090F
110	100	10	195	129	385	330	180	17	350	167	25	8	9090	VKDOM110E	VKDOM110F

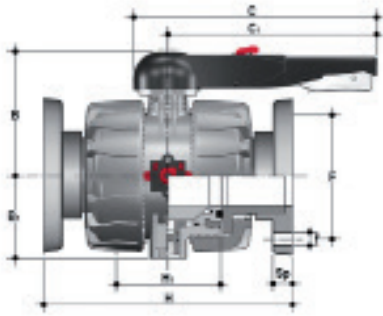

VKDOAM

DUAL BLOCK® ball valve with ANSI B16.5 cl.150#FF fixed flanges *

d	DN	PN	B	B ₁	C	C ₁	F	f	H	H ₁	Sp	U	g	EPDM code	FKM code
2 1/2"	65	10	164	87	225	175	145	17	290	133	24	4	4500	VKDOM075E	VKDOM075F
3"	80	10	177	105	327	272	160	17	310	149	25	8	6455	VKDOM090E	VKDOM090F
4"	100	10	195	129	385	330	180	17	350	167	25	8	9090	VKDOM110E	VKDOM110F

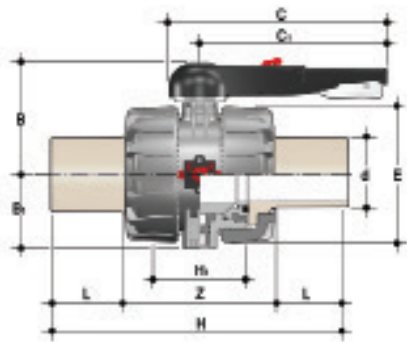

VKDBM

DUAL BLOCK® 2-way ball valve with long spigot male ends in PP-H SDR 11 for butt welding or electrofusion (CVDM)

d	DN	PN	B	B ₁	C	C ₁	E	H	H ₁	L	Z	g	EPDM code	FKM code
75	65	10	164	87	225	175	162	356	133	71	214	3150	VKDBM075E	VKDBM075F
90	80	10	177	105	327	272	202	390	149	88	214	5240	VKDBM090E	VKDBM090F
110	100	10	195	129	385	330	236	431	167	92	247	7970	VKDBM110E	VKDBM110F

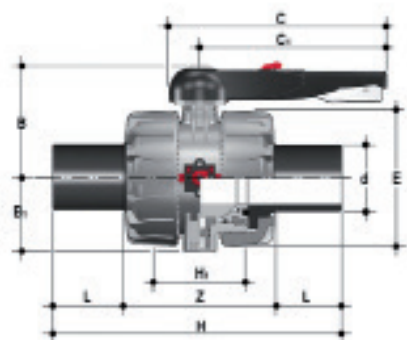

VKDBEM

DUAL BLOCK® 2-way ball valve with PE100 SDR 11 male end connectors for butt welding or electrofusion (CVDE).

d	DN	PN	B	B ₁	C	C ₁	E	H	H ₁	L	Z	g	EPDM code	FKM code
75	65	10	164	87	225	175	162	356	133	71	214	3100	VKDBEM075E	VKDBEM075F
90	80	10	177	105	327	272	202	390	149	88	214	5180	VKDBEM090E	VKDBEM090F
110	100	10	195	129	385	330	236	431	167	92	247	7800	VKDBEM110E	VKDBEM110F

ACCESSORI

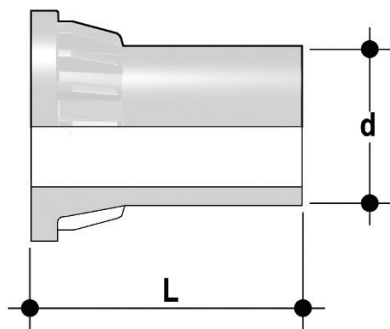

CVDM

End connectors in PP-H SDR 11 PN 10, long spigot, for butt welding

d	DN	PN	L	SDR	Code
75	65	10	111	11	CVDM11075
90	80	10	118	11	CVDM11090
110	100	10	132	11	CVDM11110

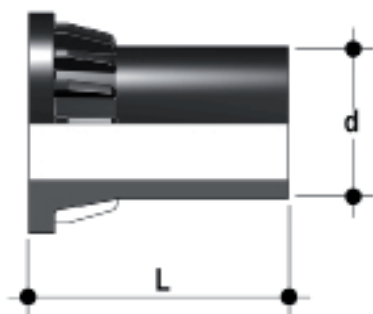

CVDE

Long spigot PE100 end connectors for joints with electrofusion fittings or for butt welding

d	DN	PN	L	SDR	Code
75	65	16	111	11	CVDE11075
90	80	16	118	11	CVDE11090
110	100	16	132	11	CVDE11110



LSE

Customisation and label printing set for Easyfit handle made up of precut adhesive sheets and software for guided label creation.

d	DN	VKD* code
75	65	LSE040
90	80	LSE040
110	100	LSE040

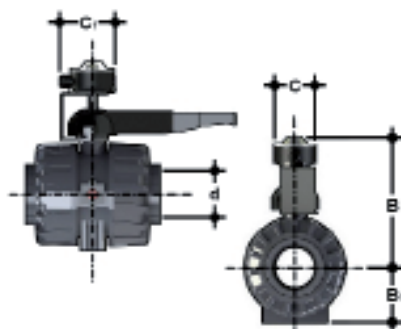

LS Quick Kit

The Limit Switch Quick Kit allows the fast and secure installation of the FIP LSQT to the VKD valves. The body is in PP-GR and the handle is in stainless steel AISI 316. The handle block at 0° and 90° is also available by default (hole diameter 6.5 mm). The kit can be assembled on the valve even if already installed on the system. For technical data of the LSQT box see FIP actuated valves catalogue.

d	DN	B	B ₁	C	C ₁	Code
75	65	275	87	103	126,9	LSQKIT75160
90	80	286,7	105	103	126,9	LSQKIT75160
110	100	305,5	129	103	126,9	LSQKIT75160

ACTUATOR MOUNTING FLANGE

The valve can be equipped with standard pneumatic or electric actuators and gearbox for heavy-duty operations, using a flange in PP-GR reproducing the drilling pattern provided for by standard ISO 5211 F07

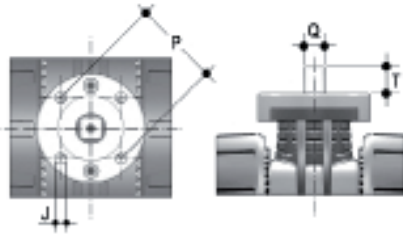

d	DN	P x J	T	Q
75	65	F07 x 9	16	14
90	80	F07 x 9	16	14
110	100	F07 x 9	19	17

FASTENING AND SUPPORTING

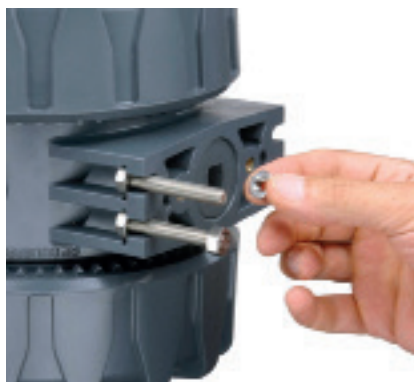

All valves, whether manual or actuated, must be adequately supported in many applications.

The VKD DN 65÷100 valve series is therefore ready to be equipped with threaded supporting brackets (optional) that permits direct anchoring on the valve body without the need of other components.

Using standard threaded nuts (not included) made of STAINLESS steel, you can anchor the valve on 4 fastening points.

d	DN	J	f	l	l1	l2
75	65	M6	6,3	17,4	90	51,8
90	80	M6	8,4	21,2	112,6	63
110	100	M8	8,4	21,2	137	67

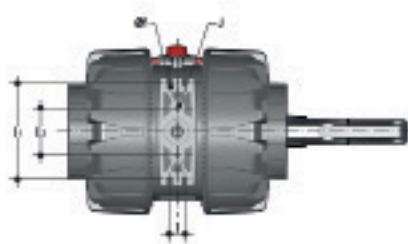

CUSTOMISATION

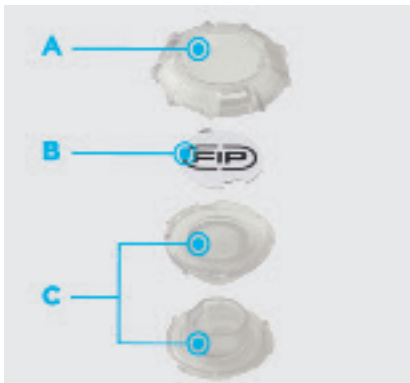

The VKD DN 65-100 valve is equipped with the customisable Labelling System. This system lets you create special labels to insert in the handle. This makes it extremely easy to apply company logos, identification serial numbers or service indications such as, for example, the valve function in the system, the transported fluid, but also specific information for customer service, such as the customer name or installation date or location on the valves.

The specific LCE module is a standard supply and is made up of a rigid transparent water-resistant PVC plug (A-C) and white tag holder (B) made of the same material, one side of which bears the FIP logo.

The holder, inserted in the plug, can be removed and, once overturned, used for customisation by applying labels printed with the software supplied with the LSE set.

Proceed as follows to apply the label on the valve:

- 1) Remove the upper part of the transparent plug (A) rotating it counter-clockwise as indicated by the "Open" label on the plug and remove it.
- 2) Extract the tag holder from its housing on the lower part of the plug (C)
- 3) Apply the adhesive label on the tag holder (B) to align the profiles matching the tab position.
- 4) Reinsert the tag holder in its housing at the bottom of the plug
- 5) Reposition the top of the plug in the housing rotating it clockwise; this way the label is protected against the elements.

COMPONENTS

EXPLODED VIEW

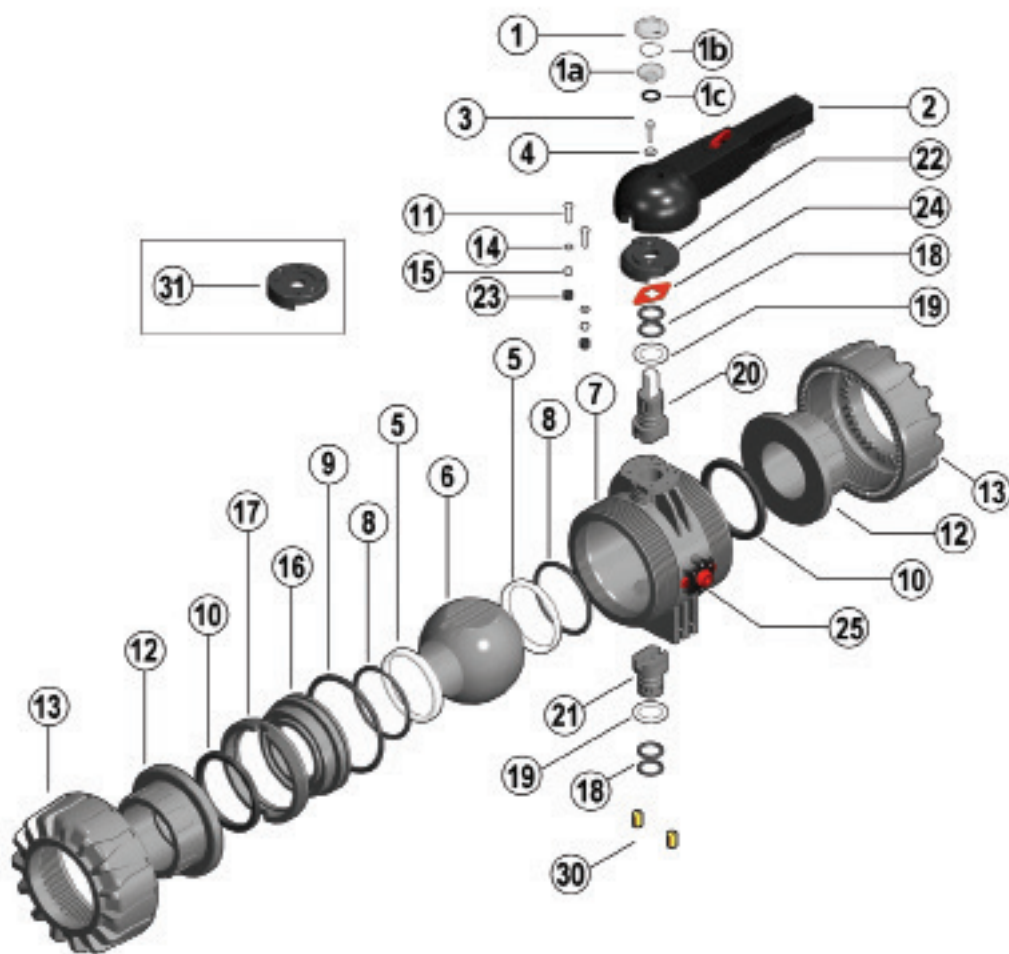

- | | | |
|---|---|--|
| 1-1a Transparent protection plug (PVC - 1) | 9 Radial seal O-Ring (EPDM or FKM - 1)* | 18 Stems O-rings (EPDM-FKM - 4)* |
| 1b Tag holder (PVC - 1) | 10 Socket seal O-Ring (EPDM or FKM - 2)* | 19 Anti-friction disk (PTFE - 2)* |
| 1c O-Ring (NBR - 1) | 11 Screw (STAINLESS steel - 2) | 20 Upper stem (PP-H/INOX - 1) |
| 2 Handle (HIPVC - 1) | 12 End connector (PP-H - 2) | 21 Lower stem (PP-H - 1) |
| 3 Screw (STAINLESS steel - 1) | 13 Union nut (PP-H - 2) | 22 Plate (PP-GR - 1) |
| 4 Washer (STAINLESS steel - 1) | 14 Washer (STAINLESS steel - 2) | 23 Protection plug (PE - 2) |
| 5 Ball seat (PTFE - 2)* | 15 Nut (STAINLESS steel - 2) | 24 Position indicator (PA - 1) |
| 6 Ball (PP-H - 1) | 16 Ball seat carrier (PP-H - 1) | 25 DUAL BLOCK® (PP-GR + vari- 1) |
| 7 Body (PP-H - 1) | 17 Threaded ring (PP-H - 1) | 30 Threaded inserts (Brass - 2)** |
| 8 Ball seat O-ring (EPDM or FKM - 2)* | | 31 Actuation plate (PP-GR - 1)** |

* Spare parts

** Accessories

The component material and quantity supplied are indicated in the parentheses.

DISASSEMBLY

- 1) Isolate the valve from the line (release the pressure and empty the pipeline).
- 2) Release the union nuts by rotating the button (25) to the left, pointing the arrow on the open lock (fig. 1).
- 3) Unscrew the union nuts (13) and extract the body (7) (fig. 2).
- 4) Before dismantling, hold the valve in a vertical position and open it 45° to drain any liquid that might remain.
- 5) Open the valve.
- 6) Remove the protection plug on the handle (2) and unscrew the screw (3) with the washer (4).
- 7) Remove the handle (2).
- 8) Remove the screws (11) and plate (22) from the body (7).
- 9) Insert the two supplied wrench protrusions in the corresponding apertures on the threaded ring (17), extracting it by rotating counterclockwise with the ball seat carrier (16) (fig. 3).
- 10) Press on the ball (6), being careful not to scratch it, and remove it from the body.
- 11) Press the upper stem (20) inwards and extract it from the body and remove the lower stem (21). Remove the anti-friction disks (19).
- 12) Remove the O-Ring (8, 9, 10, 18) and PTFE ball seats (5) extracting them from their housings, as illustrated in the exploded view.

ASSEMBLY

- 1) All the O-rings (8, 9, 10, 18) must be inserted in their grooves as shown in the exploded view.
- 2) Place the anti-friction disks (19) on the stems (20-21) and insert the stems in their housings in the body.
- 3) Place the PTFE ball seats (5) in the housings in the valve body (7) and in the carrier (16).
- 4) Insert the ball (6) rotating it to the closed position.
- 5) Insert the carrier with threaded ring (17) into the body and tighten up in the clockwise direction using the supplied tool, to limit stop.
- 6) Position the plate (22) with rack on the body, and screw in the screws (11) washers (14) and nuts (15).
- 7) The handle (2) with protection plug (1, 1a, 1b, 1c) should be placed on the stem (20) (fig. 4).
- 8) Screw in the screw (3) with the washer (4) and position the protection plug (1, 1a, 1b, 1c).
- 9) Insert the valve between the end connectors (12) and tighten the union nuts (13), making sure that the socket seal O-rings (10) do not exit their seats.
- 10) Release the union nuts by rotating the button (25) to the right, pointing the arrow on the closed lock (fig. 1).



Note: during assembly operations, it is advisable to lubricate the rubber seals. Mineral oils are not recommended for this task as they react aggressively with EPDM rubber.

Fig.1



Fig.2



Fig.3



Fig.4



INSTALLATION

Before proceeding with installation, please follow these instructions carefully:

- 1) Check that the pipes to be connected to the valve are aligned in order to avoid mechanical stress on the threaded joints.
- 2) Make sure the DUAL BLOCK® union nut lock system (25) is in the FREE position.
- 3) Unscrew the union nuts (13) and insert them on the pipe segments.
- 4) Solvent weld or screw the end connectors (12) onto the pipe ends.
- 5) Position the valve body between the end connectors and fully tighten the union nuts (13) clockwise with an appropriate wrench.
- 6) Lock the union nuts rotating the button (25) clockwise (see paragraph "union nut lock").
- 7) If necessary, support the piping with FIP pipe clips or by means of the carrier built into the valve itself (see paragraph "fastening and supporting").

Adjust the ball seat carriers using the supplied tool (fig. 3).

The seals can be installed later with the valve installed on the pipe by simply tightening the union nuts. This "micro adjustment", only possible with FIP valves thanks to the patented "Seat stop system", allows the seal to be recovered where PTFE ball seats are worn due to a high number of operations.

UNION NUT LOCK

Rotate the button to the left, pointing the arrow on the open lock to unlock DUAL BLOCK®: the valve union nuts are free to rotate clockwise and counter-clockwise. Rotate the button to the right, pointing the arrow on the closed lock to lock DUAL BLOCK®: the valve union nuts are blocked in the desired position.

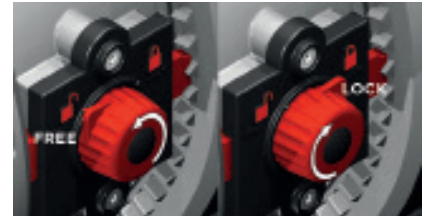

HANDLE LOCK

Thanks to the multifunctional handle and the red manoeuvre button on the lever, you can perform a 0°-90° operation and a graduated operation by means of the 10 intermediate positions and a stop lock: the handle can be locked in each of the 10 positions by simply pressing the Free-lock button. A lock can also be installed on the handle to protect the system against tampering. The valve is two-way and can be installed in any position. It can also be installed at end line or tank.



WARNINGS

If volatile liquid such as Hydrogen Peroxide (H₂O₂) or Sodium Hypochlorite (NaClO) are used, for safety reasons we recommend you contact the service centre. These liquids, upon vaporising, could create hazardous over pressures in the area between the body and ball.

Always avoid sudden closing operations and protect the valve from accidental operations.