

Stack-aerator

The dBlue stack-aerator is available with 6 possible horizontal branch connections that are closed with a cap. The sockets required for the horizontal connections need to be butt-welded on the stack-aerator. Specify configuration when ordering.

- 3 x d2 : 110 mm
- 3 x d3 : 75 mm

Opposite connections are not permitted.

Always use plug-in sockets for the horizontal connections and expansion sockets for the vertical connection on top.

- d1 75 mm - Code VVEN-KIE-075-00D - dBlue plug-in socket (75 mm)
- d1 110 mm - Code VVEN-KIE-110-00D - dBlue plug-in socket (110 mm)
- d1 110 mm - Code VVEN-WLO-110-00D - dBlue expansion socket (110 mm)
- d1 160 mm - Code VVEN-WLO-160-00D - dBlue expansion socket (160 mm)

Inspection openings should be installed according to local regulation. We advise one on every level.

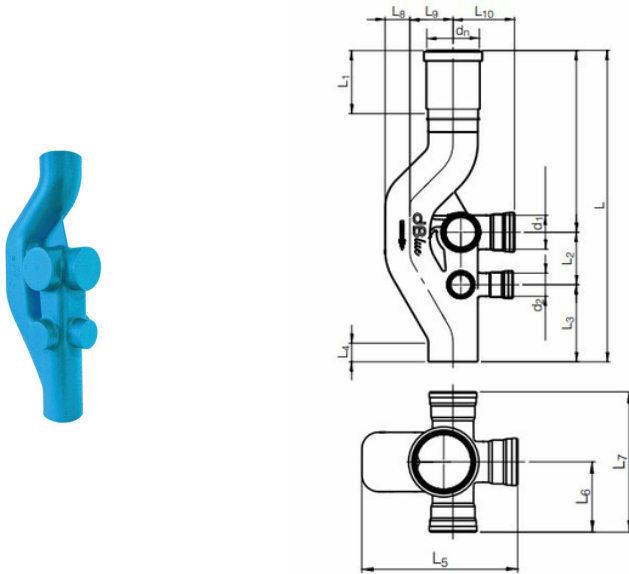

DN (mm)	d1	d2	L (mm)	L1	L2	L3	L4	L5	L6	L7	L8	L9	L10
110	110	75	956	256	170	240	60	344	159				
										313	55	130	159
160	110	75	1010	256	170	250	60	404	179				
										358	80	140	184

Reference	Q	Subcategory	Diameters
VVEN-110-110-75D	1	Branches	110, 160
VVEN-160-110-75D	1	Branches	110, 160